

Service Manual



Part 1

General Information

1. Indoor and Outdoor Units.....	2
2. External Appearance.....	2

1. Indoor and Outdoor Units

Series	Capacity	Outdoor units	Indoor units
15 SEER ON/OFF	18K	ATSCV4C4T18	ATSEM4H4T18
		ATSCV4H4T18	ATSFR4H4T18
	24K	ATSCV4C4T24	ATSEM4H4T24
		ATSCV4H4T24	ATSFR4H4T24
	30K	ATSCV4C4T30	ATSEM4H4T30
		ATSCV4H4T30	ATSFR4H4T30
	36K	ATSCV4C4T36	ATSEM4H4T36
		ATSCV4H4T36	ATSFR4H4T36
	42K	ATSCV4C4T42	ATSEM4H4T42
		ATSCV4H4T42	
	48K	ATSCV4C4T48	ATSEM4H4T48
		ATSCV4H4T48	
	60K	ATSCV4C4T60	ATSEM4H4T60
		ATSCV4H4T60	

2. External Appearance

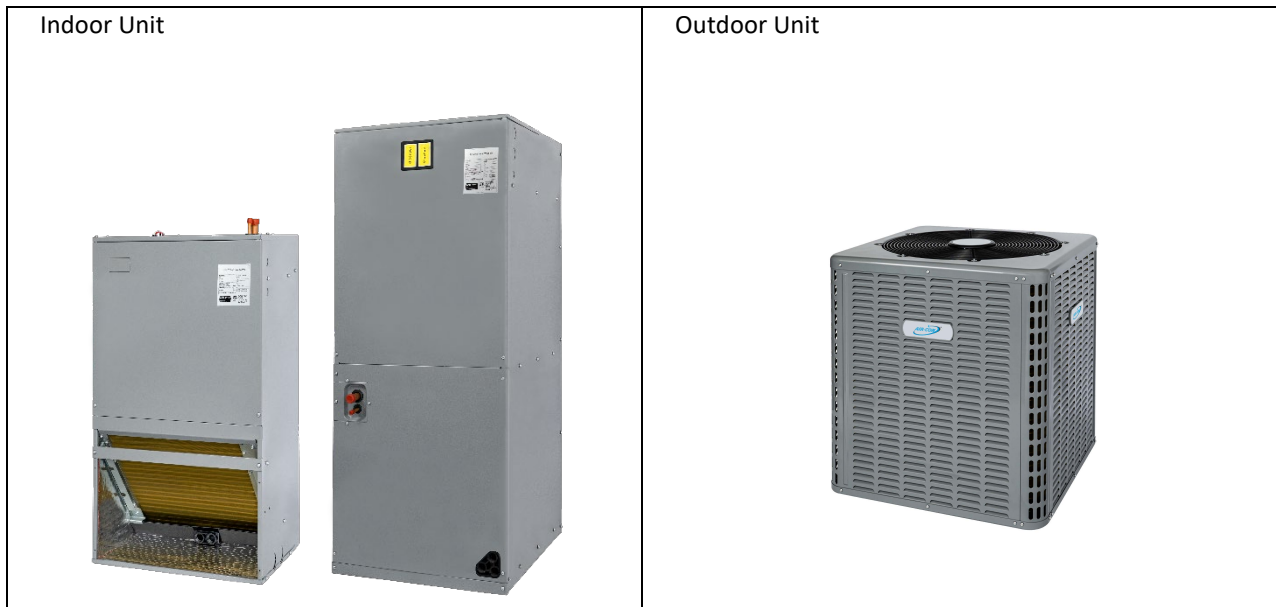

Part 2

Engineering Data

1. Specifications	4
2. Dimensions	11
3. Installation Space Requirements	14
4. Piping Diagrams	16
5. Wiring Diagrams	17
6. Capacity Tables	21
7. Accessories	25

1. Specifications

1.1 Outdoor Units

Model			ATSCV4C4T18	ATSCV4C4T24	ATSCV4C4T30
Outdoor power supply		V/Ph/Hz	208/230/1/60		
Cooling	Capacity	Btu/h	17500	23400	28000
	Input	W	1550	2000	2350
	EER2	Btu/(h·W)	11.7	11.7	11.7
	SEER2 (AHRI Certified)	Btu/(h·W)	14.3	14.3	14.3
Heating	Capacity	Btu/h	–	–	–
	HSPF2 (AHRI Certified)	Btu/(h·W)	–	–	–
Max. input consumption		W	2250	3050	3300
Max. current		A	11.5	15.0	17.0
Compressor	Brand		LG	LG	LG
	Model		APG016KAC	APG020KAC	APG024KAC
	Type		Scroll	Scroll	Scroll
	Capacity	Btu/h	19300	24800	29500
	Input	W	1290	1570	1870
	Rated current (RLA)	A	5.6	6.9	8.2
	Locked rotor Amp (LRA)	A	48	52	63
	Thermal protector	μF	35	35	40
Refrigerant oil	ml	740	740	740	
Outdoor fan motor	Brand		GREEN-INTELLIGENCE	GREEN-INTELLIGENCE	GREEN-INTELLIGENCE
	Type		AC	AC	AC
	Input	W	162	162	226
	Output	W	85	85	160
	Capacitor	μF	6	6	6
	Speed	rpm	950	950	1050
Outdoor coil	Number of row		2	2	2
	Fin spacing	in	1/18	1/18	1/18
	Fin material		Hydrophilic Aluminium Fin	Hydrophilic Aluminium Fin	Hydrophilic Aluminium Fin
	Tube outside diameter	mm	Φ 7	Φ 7	Φ 7
	Tube type		Inner Grooved	Inner Grooved	Inner Grooved
	Coil length x height x width	in	61.7×23.15×1.05	61.7×23.15×1.05	61.7×23.15×1.05
	Number of circuit		6	6	6
Outdoor air flow		CFM	2000	2000	2250
Outdoor sound pressure level		dB(A)	60	60	63
Outdoor dimension	Unit (W*H*D)	in	23-3/5×25×23-3/5	23-3/5×25×23-3/5	23-3/5×25×23-3/5
		mm	600×635×600	600×635×600	600×635×600
	Packing (W*H*D)	in	24-4/5×26-1/5×24-4/5	24-4/5×26-1/5×24-4/5	24-4/5×26-1/5×24-4/5
		mm	630×665×630	630×665×630	630×665×630
	Net / Gross weight	kg	54.5/57	55.5/58	63/65.5
lbs		120/126	122/128	137/144	
Refrigerant	Type		R410A	R410A	R410A
	Charging volume	oz	93.5	102.3	102.3
Refrigerant pipe	Liquid side	in	Φ3/8	Φ3/8	Φ3/8
	Gas side	in	Φ3/4	Φ3/4	Φ3/4
	Max. refrigerant pipe length	ft	148	148	148
	Max. difference in level	ft	66	66	66
Design pressure		MPa	2.7/1.0	2.7/1.0	2.8/1.0
Max. pressure		MPa	4.5	4.5	4.5
Operation temp range	Cooling	°F	64-118	64-118	64-118
	Heating	°F	/	/	/

Model			ATSCV4C4T36	ATSCV4C4T42	ATSCV4C4T48	ATSCV4C4T60
Outdoor power supply		V/Ph/Hz	208/230/1/60			
Cooling	Capacity	Btu/h	33000	40000	45000	55500
	Input	W	2750	3440	3800	4920
	EER2	Btu/(h·W)	11.7	11.7	11.2	11.2
	SEER2 (AHRI Certified)	Btu/(h·W)	14.3	14.3	13.8	13.8
Heating	Capacity	Btu/h	—	—	—	—
	HSPF2 (AHRI Certified)	Btu/(h·W)	—	—	—	—
Max. input consumption		W	4455	5430	6000	7300
Max. current		A	23.0	28.0	29.5	37.0
Compressor	Brand		LG	LG	LG	LG
	Model		APG029KAC	ABG036KAC	ABG039KAC	ABG051KAC
	Type		Scroll	Scroll	Scroll	Scroll
	Capacity	Btu/h	35800	44700	48200	63000
	Input	W	2200	2790	3000	3830
	Rated current (RLA)	A	9.8	12.3	13.7	17.4
	Locked rotor Amp (LRA)	A	79.0	112.3	94.0	127.9
	Thermal protector	μF	45	45	70	70
	Refrigerant oil	ml	740	1280	1280	1280
Outdoor fan motor	Brand		GREEN-INTELLIGENCE	GREEN-INTELLIGENCE	GREEN-INTELLIGENCE	GREEN-INTELLIGENCE
	Type		AC	AC	AC	AC
	Input	W	197	210	370	370
	Output	W	110	110	230	230
	Capacitor	μF	6	6	12	12
	Speed	rpm	850	850	1050	1050
Outdoor coil	Number of row		2	2	2	2
	Fin spacing	in	1/18	1/18	1/18	1/18
	Fin material		Hydrophilic Aluminium Fin	Hydrophilic Aluminium Fin	Hydrophilic Aluminium Fin	Hydrophilic Aluminium Fin
	Tube outside diameter	mm	φ 7	φ 7	φ 7	φ 7
	Tube type		Inner Grooved	Inner Grooved	Inner Grooved	Inner Grooved
	Coil length x height x width	in	83.8×23.15×1.05	83.8×31.48×1.05	83.8×31.48×1.05	83.8×31.48×1.05
	Number of circuit		6	10	10	10
Outdoor air flow		CFM	2750	3300	4000	4000
Outdoor sound pressure level		dB(A)	63	65	65	63
Outdoor dimension	Unit (W*H*D)	in	29-1/7×25×29-1/7	29-1/7×32-7/8×29-1/7	29-1/7×32-7/8×29-1/7	29-1/7×32-7/8×29-1/7
		mm	740×635×740	740×835×740	740×835×740	740×835×740
	Packing (W*H*D)	in	30-3/10×26-1/5×30-3/10	30-3/10×34-4/5×30-3/10	30-3/10×34-4/5×30-3/10	30-3/10×34-4/5×30-3/10
		mm	770×665×770	770×885×770	770×885×770	770×885×770
	Net / Gross weight	kg	72.5/75.5	90/95	92/97	93/98
		lbs	160/166	198/209	203/214	205/216
Refrigerant	Type		R410A	R410A	R410A	R410A
	Charging volume	oz	116.4	151.7	158.7	162.3
Refrigerant pipe	Liquid side	in	φ3/8	φ3/8	φ3/8	φ3/8
	Gas side	in	φ3/4	φ3/4	φ7/8	φ7/8
	Max. refrigerant pipe length	ft	148	148	148	148
	Max. difference in level	ft	66	66	66	66
Design pressure		MPa	2.7/1.0	2.7/1.0	2.8/1.0	2.8/1.0
Max. pressure		MPa	4.5	4.5	4.5	4.5
Operation temp range	Cooling	°F	64-118	64-118	64-118	64-118
	Heating	°F	/	/	/	/

Model			ATSCV4H4T18	ATSCV4H4T24	ATSCV4H4T30
Outdoor power supply		V/Ph/Hz	208/230/1/60		
Cooling	Capacity	Btu/h	17500	22000	28000
	Input	W	1550	2000	2370
	EER2	Btu/(h·W)	11.5	11.2	11.5
	SEER2 (AHRI Certified)	Btu/(h·W)	14.3	14.3	14.3
Heating	Capacity	Btu/h	17500	22000	26000
	HSPF2(AHRI Certified)	Btu/(h·W)	7.5	7.5	7.5
Max. input consumption		W	2250	3050	3300
Max. current		A	11.5	15.0	17.0
Compressor	Brand		LG	LG	LG
	Model		APG016KAC	APG020KAC	APG024KAC
	Type		Scroll	Scroll	Scroll
	Capacity	Btu/h	19300	24800	29500
	Input	W	1290	1570	1870
	Rated current (RLA)	A	5.6	6.9	8.2
	Locked rotor Amp (LRA)	A	48	52	63
	Thermal protector	μF	35	35	40
Refrigerant oil	ml	740	740	740	
Outdoor fan motor	Brand		GREEN-INTELLIGENCE	GREEN-INTELLIGENCE	GREEN-INTELLIGENCE
	Model		AC	AC	AC
	Input	W	162	162	226
	Output	W	85	85	160
	Capacitor	μF	6	6	6
	Speed	rpm	950	950	1050
Outdoor coil	Number of row		2	2	2
	Fin spacing	in	1/18	1/18	1/18
	Fin material		Hydrophilic Aluminium Fin	Hydrophilic Aluminium Fin	Hydrophilic Aluminium Fin
	Tube outside diameter	mm	Φ7	Φ7	Φ7
	Tube type		Inner Grooved	Inner Grooved	Inner Grooved
	Coil length x height x width	in	61.7×23.15×1.05	61.7×23.15×1.05	61.7×23.15×1.05
	Number of circuit		6	6	6
Outdoor air flow		CFM	2000	2000	2250
Outdoor sound pressure level		dB(A)	60	60	63
Outdoor dimension	Unit (W*H*D)	in	23-3/5×25×23-3/5	23-3/5×25×23-3/5	23-3/5×25×23-3/5
		mm	600×635×600	600×635×600	600×635×600
	Packing (W*H*D)	in	24-4/5×26-1/5×24-4/5	24-4/5×26-1/5×24-4/5	24-4/5×26-1/5×24-4/5
		mm	630×665×630	630×665×630	630×665×630
	Net / Gross weight	kg	57.5/60	58.5/61	66/68.5
		lbs	127/132	129/134	146/151
Refrigerant	Type		R410A	R410A	R410A
	Charging volume	oz	93.5	98.8	105.8
Refrigerant pipe	Liquid side	in	Φ3/8	Φ3/8	Φ3/8
	Gas side	in	Φ3/4	Φ3/4	Φ3/4
	Max. refrigerant pipe length	ft	148	148	148
	Max. difference in level	ft	66	66	66
Design pressure		MPa	2.7/1.0	2.7/1.0	2.8/1.0
Max. pressure		MPa	4.5	4.5	4.5
Operation temp range	Cooling	°F	64-118	64-118	64-118
	Heating	°F	17-80	17-80	17-80

Model			ATSCV4H4T36	ATSCV4H4T42	ATSCV4H4T48	ATSCV4H4T60
Outdoor power supply		V/Ph/Hz	208/230/1/60			
Cooling	Capacity	Btu/h	33000	40000	45000	56000
	Input	W	2780	3400	3770	4870
	EER2	Btu/(h-W)	11.5	11.5	11.5	11.5
	SEER2 (AHRI Certified)	Btu/(h-W)	14.3	14.3	14.3	14.3
Heating	Capacity	Btu/h	33000	40000	44000	53000
	HSPF2(AHRI Certified)	Btu/(h-W)	7.5	7.5	7.5	7.5
Max. input consumption		W	4455	5430	6000	7300
Max. current		A	23.0	28.0	29.5	37.0
Compressor	Brand		LG	LG	LG	LG
	Model		APG029KAC	ABG036KAC	ABG039KAC	ABG051KAC
	Type		Scroll	Scroll	Scroll	Scroll
	Capacity	Btu/h	35800	44700	48200	63000
	Input	W	2200	2790	3000	3830
	Rated current (RLA)	A	9.8	12.3	13.7	17.4
	Locked rotor Amp (LRA)	A	79.0	112.3	94.0	127.9
	Thermal protector	μF	45	45	70	70
	Refrigerant oil	ml	740	1280	1280	1280
Outdoor fan motor	Brand		GREEN-INTELLIGENCE	GREEN-INTELLIGENCE	GREEN-INTELLIGENCE	Panasonic/ Broad-Ocean
	Model		AC	AC	AC	DC
	Input	W	197	210	370	270
	Output	W	110	110	230	200
	Capacitor	μF	6	6	12	/
	Speed	rpm	850	850	1050	1050
Outdoor coil	Number of row		2	2	2	2.5
	Fin spacing	in	1/18	1/18	1/18	1/18
	Fin material		Hydrophilic Aluminium Fin	Hydrophilic Aluminium Fin	Hydrophilic Aluminium Fin	Hydrophilic Aluminium Fin
	Tube outside diameter	mm	φ7	φ7	φ7	φ7
	Tube type		Inner Grooved	Inner Grooved	Inner Grooved	Inner Grooved
	Coil length x height x width	in	83.8×23.15×1.05	83.8×31.48×1.05	83.8×31.48×1.05	83.8×31.48×1.58
	Number of circuit		6	10	10	8
Outdoor air flow		CFM	2750	3300	4000	4000
Outdoor sound pressure level		dB(A)	63	65	65	63
Outdoor dimension	Unit (W*H*D)	in	29-1/7×25×29-1/7	29-1/7×32-7/8×29-1/7	29-1/7×32-7/8×29-1/7	29-1/7×32-7/8×29-1/7
		mm	740×635×740	740×835×740	740×835×740	740×835×740
	Packing (W*H*D)	in	30-3/10×26-1/5×30-3/10	30-3/10×34-4/5×30-3/10	30-3/10×34-4/5×30-3/10	30-3/10×34-4/5×30-3/10
		mm	770×665×770	770×885×770	770×885×770	770×885×770
	Net / Gross weight	kg	75.5/78.5	94/99	97/102	104/109
		lbs	166/173	207/218	214/225	229/240
Refrigerant	Type		R410A	R410A	R410A	R410A
	Charging volume	oz	123.5	151.7	162.3	197.5
Refrigerant pipe	Liquid side	in	φ3/8	φ3/8	φ3/8	φ3/8
	Gas side	in	φ3/4	φ3/4	φ7/8	φ7/8
	Max. refrigerant pipe length	ft	148	148	148	148
	Max. difference in level	ft	66	66	66	66
Design pressure		MPa	2.7/1.0	2.7/1.0	2.8/1.0	2.8/1.0
Max. pressure		MPa	4.5	4.5	4.5	4.5
Operation temp range	Cooling	°F	64-118	64-118	64-118	64-118
	Heating	°F	17-80	17-80	17-80	17-80

1.2 Indoor Units

Model			ATSEM4H4T18	ATSEM4H4T24	ATSEM4H4T30
Power supply		V/Ph/Hz	208/230/1/60		
Cooling	Capacity	Btu/h	17500	22000	28000
	SEER2	Btu/(h·W)	14.3	14.3	14.3
Indoor external static pressure		Pa	125	125	125
Throttle type			Orifice	Orifice	Orifice
Indoor coil	Number of row		3(row)×2(piece)	4(row)×2(piece)	4(row)×2(piece)
	Tube pitch(a) x row pitch(b)	in	0.83×0.53	0.83×0.53	0.83×0.53
	Fin spacing	in	1/17	1/17	1/17
	Fin material		Hydrophilic Aluminium Fin	Hydrophilic Aluminium Fin	Hydrophilic Aluminium Fin
	Tube outside diameter	mm	Φ7	Φ7	Φ7
	Tube type		Inner Grooved	Inner Grooved	Inner Grooved
	Coil length x height x width	in	17.36×14.88×1.58	17.36×16.54×2.11	17.36×16.54×2.11
	Number of circuit		6	8	8
Indoor fan motor	Brand		Kangbao	Kangbao	Genteq/Wolong/Broad-Ocean
	Type		AC	AC	ECM
	Input	W	265	398	267
	Output	W	180	220	373
	Capacitor	μF	6	10	/
	Speed	rpm	830	910	960
Blower	Diameter	in	11	11	11
	Width	in	11	11	11
Indoor air flow		CFM	580	800	980
Indoor sound pressure level		dB(A)	/	/	/
Indoor dimension	Unit (W*H*D)	in	19-2/3×45-3/4×22	19-2/3×45-3/4×22	19-2/3×45-3/4×22
		mm	500×1162×560	500×1162×560	500×1162×560
	Packing (W*H*D)	in	22-5/6×47-5/8×25-3/5	22-5/6×47-5/8×25-3/5	22-5/6×47-5/8×25-3/5
		mm	580×1210×650	580×1210×650	580×1210×650
	Net / Gross weight	kg	57/62	60/65	59/64
		lbs	126/137	132/143	130/141
Refrigerant pipe	Liquid side	in	3/8	3/8	3/8
	Gas side	in	3/4	3/4	3/4

Model			ATSEM4H4T36	ATSEM4H4T42	ATSEM4H4T48	ATSEM4H4T60
Power supply		V/Ph/Hz	208/230/1/60			
Cooling	Capacity	Btu/h	33000	40000	45000	55500
	SEER2	Btu/(h·W)	14.3	14.3	13.8/14.3	13.8/14.3
Indoor external static pressure		Pa	125	125	125	125
Throttle type			Orifice	Orifice	Orifice	Orifice
Indoor coil	Number of row		4(row)×2(piece)	4(row)×2(piece)	4(row)×2(piece)	5(row)×2(piece)
	Tube pitch(a) x row pitch(b)	in	0.83×0.53	0.83×0.53	0.83×0.53	0.83×0.53
	Fin spacing	in	1/17	1/17	1/17	1/17
	Fin material		Hydrophilic Aluminium Fin	Hydrophilic Aluminium Fin	Hydrophilic Aluminium Fin	Hydrophilic Aluminium Fin
	Tube outside diameter	mm	Φ7	Φ7	Φ7	Φ7
	Tube type		Inner Grooved	Inner Grooved	Inner Grooved	Inner Grooved
	Coil length x height x width	in	17.36×16.54×2.11	17.36×16.54×2.11	19.84×21.5×2.11	19.84×21.5×2.63
Number of circuit			8	8	12	12
Indoor fan motor	Brand		Genteq/Wolong/Broad-Ocean	Genteq/Wolong/Broad-Ocean	Genteq/Wolong/Broad-Ocean	Genteq/Wolong/Broad-Ocean
	Type		ECM	ECM	ECM	ECM
	Input	W	317	317	365	473
	Output	W	373	560	560	560
	Capacitor	μF	/	/	/	/
	Speed	rpm	1000	1040	1010	1010
Blower	Diameter	in	11	11	11	11
	Width	in	11	11	11	11
Indoor air flow		CFM	1150	1280	1580	1570
Indoor sound pressure level		dB(A)	/	/	/	/
Indoor dimension	Unit (W*H*D)	in	19-2/3×45-3/4×22	19-2/3×45-3/4×22	22×53-1/8×24	22×53-1/8×24
		mm	500×1162×560	500×1162×560	560×1350×623	560×1350×623
	Packing (W*H*D)	in	22-5/6×47-5/8×25-3/5	22-5/6×47-5/8×25-3/5	27-3/4×54-9/10×25-1/5	27-3/4×54-9/10×25-1/5
		mm	580×1210×650	580×1210×650	705×1395×640	705×1395×640
	Net / Gross weight	kg	59/64	61/66	78/84	78/84
lbs		130/141	134/146	172/185	172/185	
Refrigerant pipe	Liquid side	in	3/8	3/8	3/8	3/8
	Gas side	in	3/4	3/4	7/8	7/8

Model			ATSFR4H4T18	ATSFR4H4T24	ATSFR4H4T30	ATSFR4H4T36
Power supply		V/Ph/Hz	208/230/1/60			
Cooling	Capacity	Btu/h	17500	22000	28000	33000
	SEER2	Btu/(h·W)	14.3	14.3	14.3	14.3
Indoor external static pressure		Pa	145	145	145	145
Throttle type			Orifice	Orifice	Orifice	Orifice
Indoor coil	Number of row		5	5	5	5
	Tube pitch(a) x row pitch(b)	in	0.83×0.53	0.83×0.53	0.83×0.53	0.83×0.53
	Fin spacing	in	1/17	1/17	1/17	1/17
	Fin material		Hydrophilic Aluminium Fin	Hydrophilic Aluminium Fin	Hydrophilic Aluminium Fin	Hydrophilic Aluminium Fin
	Tube outside diameter	mm	Φ7	Φ7	Φ7	Φ7
	Tube type		Inner Grooved	Inner Grooved	Inner Grooved	Inner Grooved
	Coil length x height x width	in	16.97×18.2×2.63	16.97×18.2×2.63	17.44×23.15×2.63	17.44×23.15×2.63
Number of circuit			6	6	8	8
Indoor fan motor	Brand		Genteq/Wolong/Broad-Ocean	Genteq/Wolong/Broad-Ocean	Genteq/Wolong/Broad-Ocean	Genteq/Wolong/Broad-Ocean
	Type		ECM	ECM	ECM	ECM
	Input	W	166	221	267	317
	Output	W	249	249	373	373
	Capacitor	μF	/	/	/	/
	Speed (Hi/Me/Lo)	rpm	960	1010	960	1000
Blower	Diameter	in	11	11	11	11
	Width	in	10	10	6	6
Indoor air flow		CFM	715	805	1020	1145
Indoor sound pressure level		dB(A)	/	/	/	/
Indoor dimension	Unit (W*H*D)	in	20-3/5×36×15	20-3/5×36×15	22-1/10×39-3/5×19	22-1/10×39-3/5×19
		mm	522×915×381	522×915×381	559×1006×485	559×1006×485
	Packing (W*H*D)	in	23-1/5×39-2/5×17-7/10	23-1/5×39-2/5×17-7/10	24-3/5×42-9/10×21-3/5	24-3/5×42-9/10×21-3/5
		mm	590×1000×450	590×1000×450	625×1090×550	625×1090×550
	Net / Gross weight	kg	40/44	40/44	51/56	51/56
lbs		88/97	88/97	112/123	112/123	
Refrigerant pipe	Liquid side	in	3/8	3/8	3/8	3/8
	Gas side	in	3/4	3/4	3/4	3/4

2. Dimensions

2.1 Outdoor Units

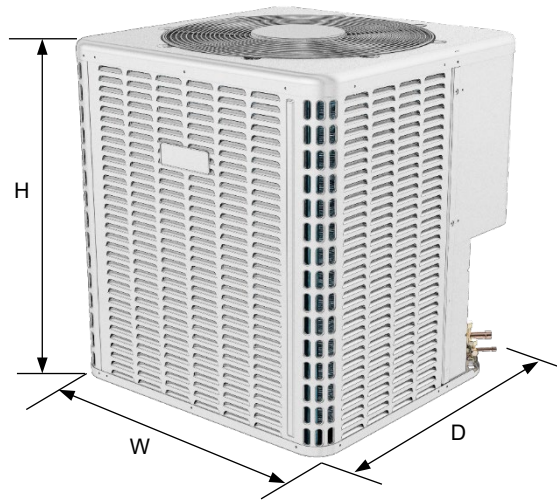

Model name	Dimensions		
	"W" mm (in.)	"D" mm (in.)	"H" mm (in.)
ATSCV4C4T18 ATSCV4H4T18	600 (23-5/8)	600 (23-5/8)	635 (25)
ATSCV4C4T24 ATSCV4H4T24			
ATSCV4C4T30 ATSCV4H4T30			
ATSCV4C4T36 ATSCV4H4T36	740 (29-1/8)	740 (29-1/8)	635 (25)
ATSCV4C4T42 ATSCV4H4T42	740 (29-1/8)	740 (29-1/8)	835 (32-7/8)
ATSCV4C4T48 ATSCV4H4T48			
ATSCV4C4T60 ATSCV4H4T60			

2.2 Indoor Units

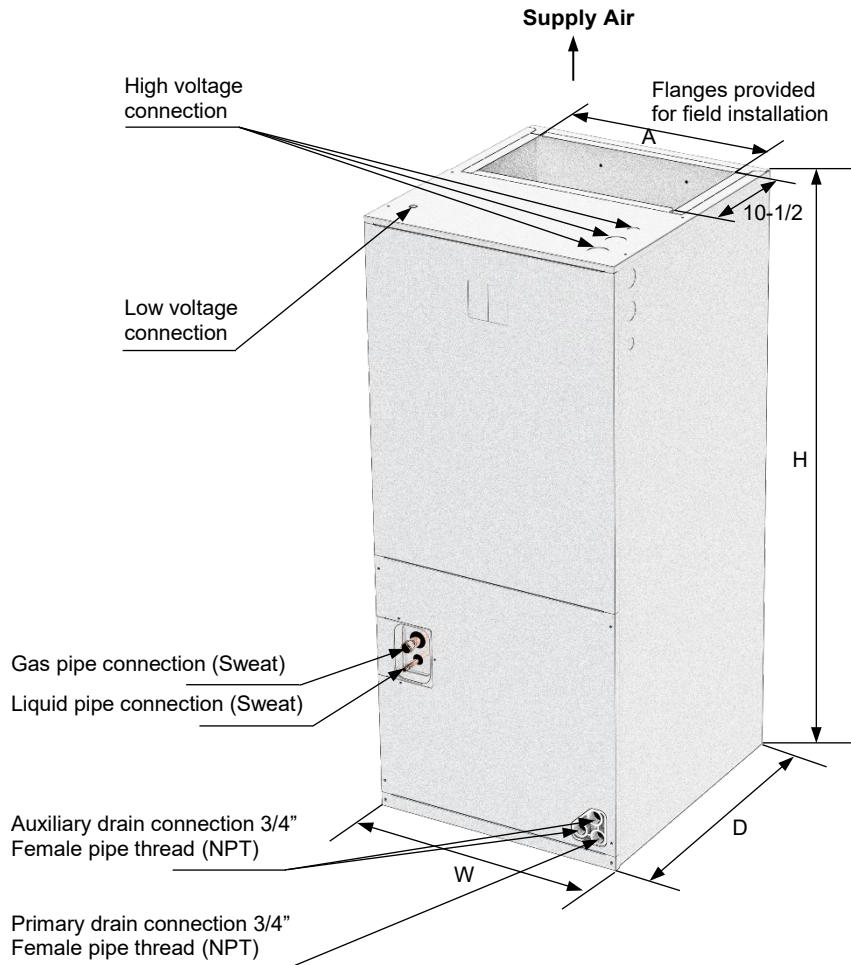

**Upflow unit shown;
Unit may be installed upflow, downflow,
horizontal right, or left air supply.**

Model name	Dimensions			
	"W" mm (in.)	"D" mm (in.)	"H" mm (in.)	Supply duct "A" mm (in.)
ATSEM4H4T18	500 (19-2/3)	560 (22)	1162 (45-3/4)	454 (17-7/8)
ATSEM4H4T24				
ATSEM4H4T30				
ATSEM4H4T36				
ATSEM4H4T42	560 (22)	623 (24-1/2)	1350 (53-1/8)	496 (19-1/2)
ATSEM4H4T48				
ATSEM4H4T60				

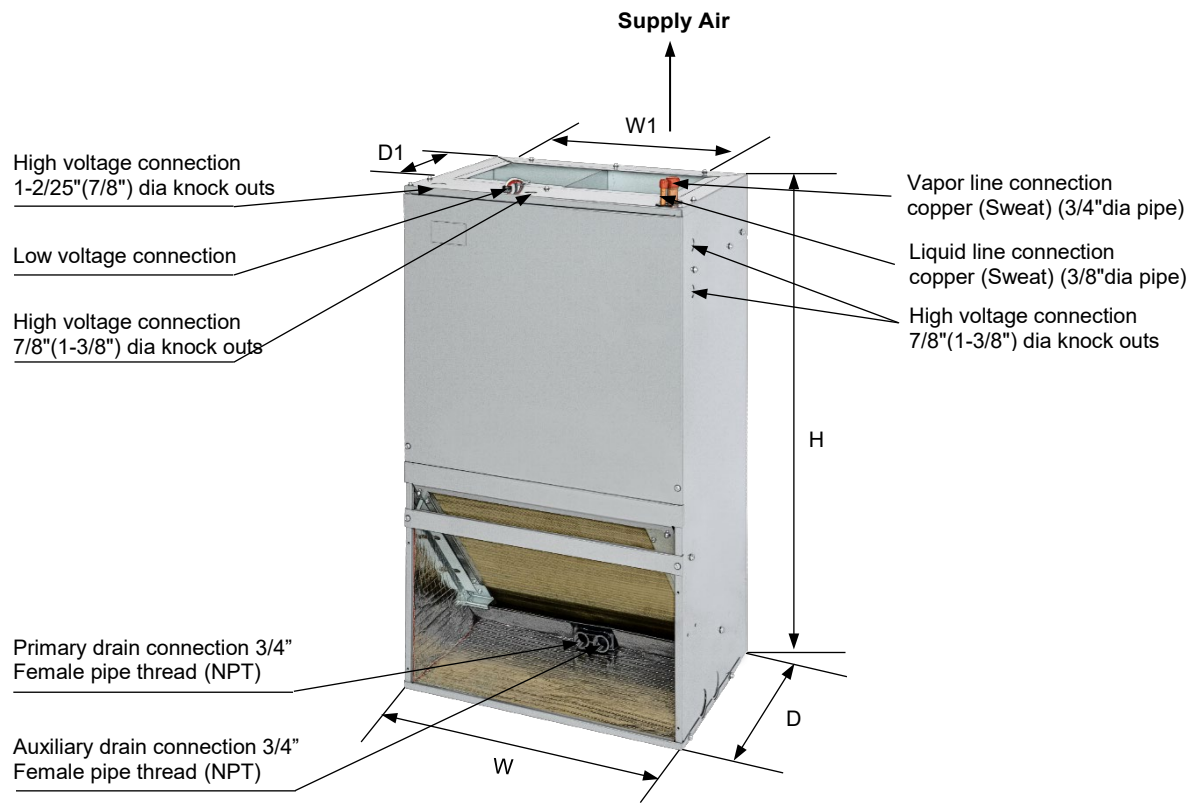

**All units are configured for vertical upflow.
Units cannot be installed in any other configuration.**

Front return shown. Units may also be installed as bottom return. See the applications section for more details.

Model name	Dimensions				
	"W" mm (in.)	"W1" mm (in.)	"D" mm (in.)	"D1" mm (in.)	"H" mm (in.)
ATSF4H4T18	522 (20-1/2)	442 (17-2/5)	381 (15)	244 (9-3/5)	915 (36)
ATSF4H4T24					
ATSF4H4T30	559 (22)	477 (18-4/5)	485 (19)	251 (10)	1006 (39-3/5)
ATSF4H4T36					

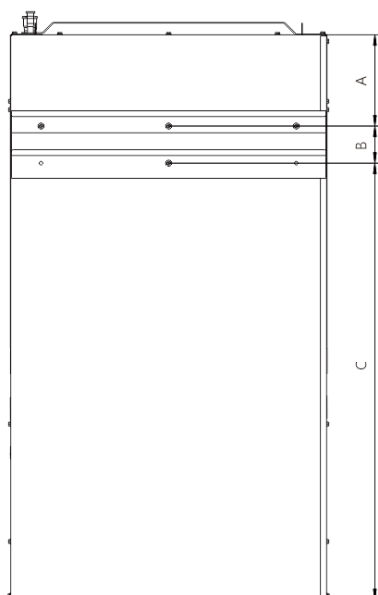

Model name	Dimensions		
	"A" mm (in.)	"B" mm (in.)	"C" mm (in.)
ATSF4H4T18	136 (5-3/8)	61 (2-2/5)	718 (28-1/4)
ATSF4H4T24			
ATSF4H4T30	151 (6)	61 (2-2/5)	794 (31-1/4)
ATSF4H4T36			

3. Installation Space Requirements

3.1 Outdoor Units

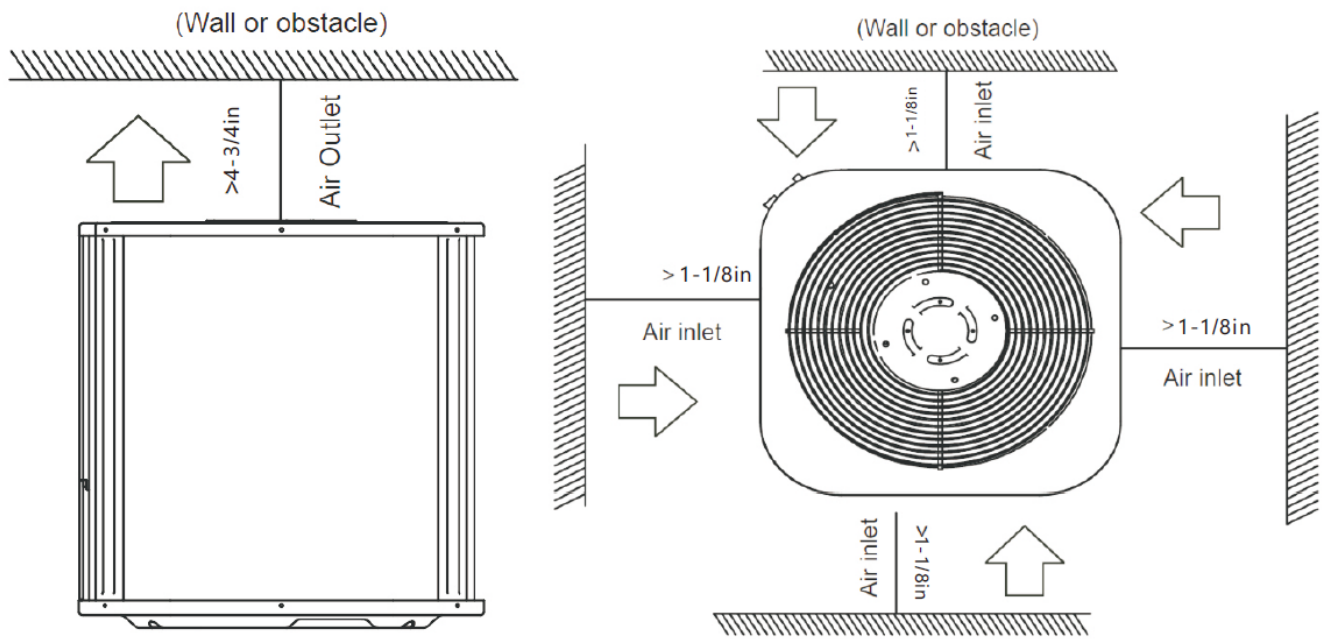

3.2 Indoor Units

Regular Air Handler:

Horizontal position:

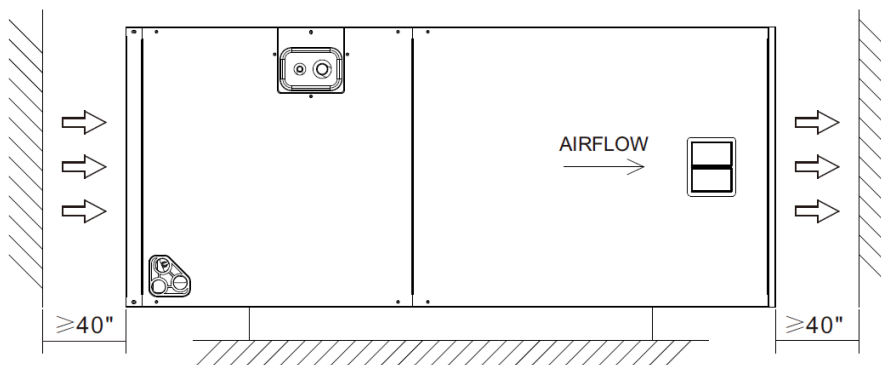

Vertical position:

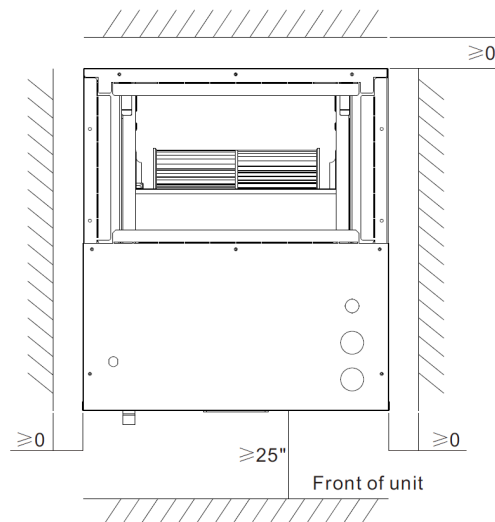

Front Return Air Handler:

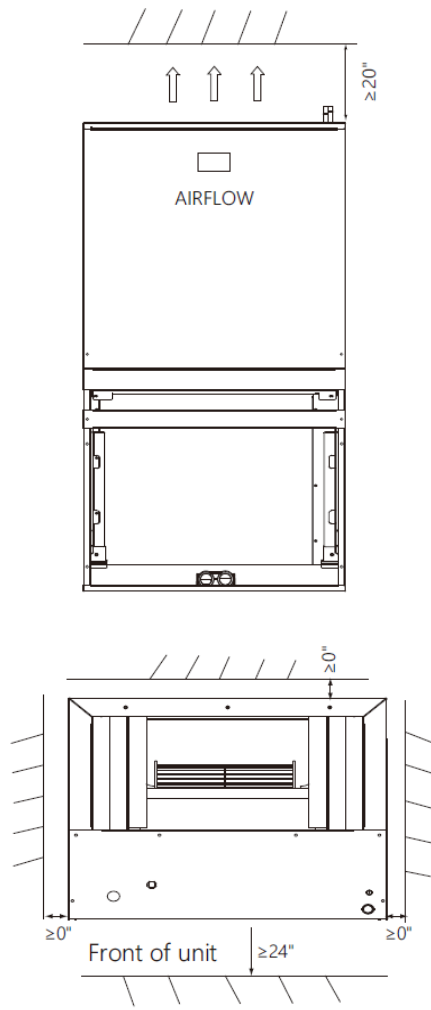

4. Piping Diagrams

Cooling only models:

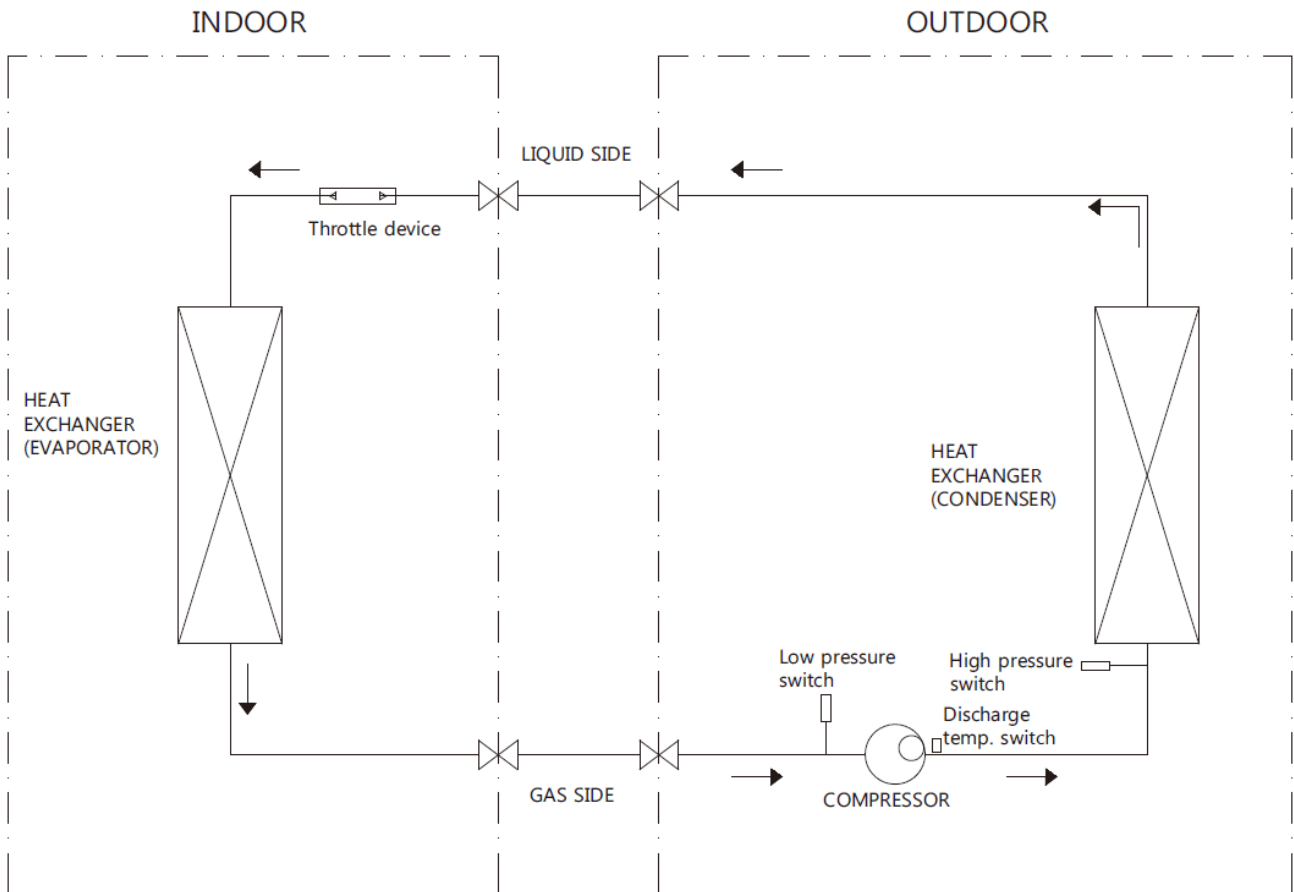

Heat pump models:

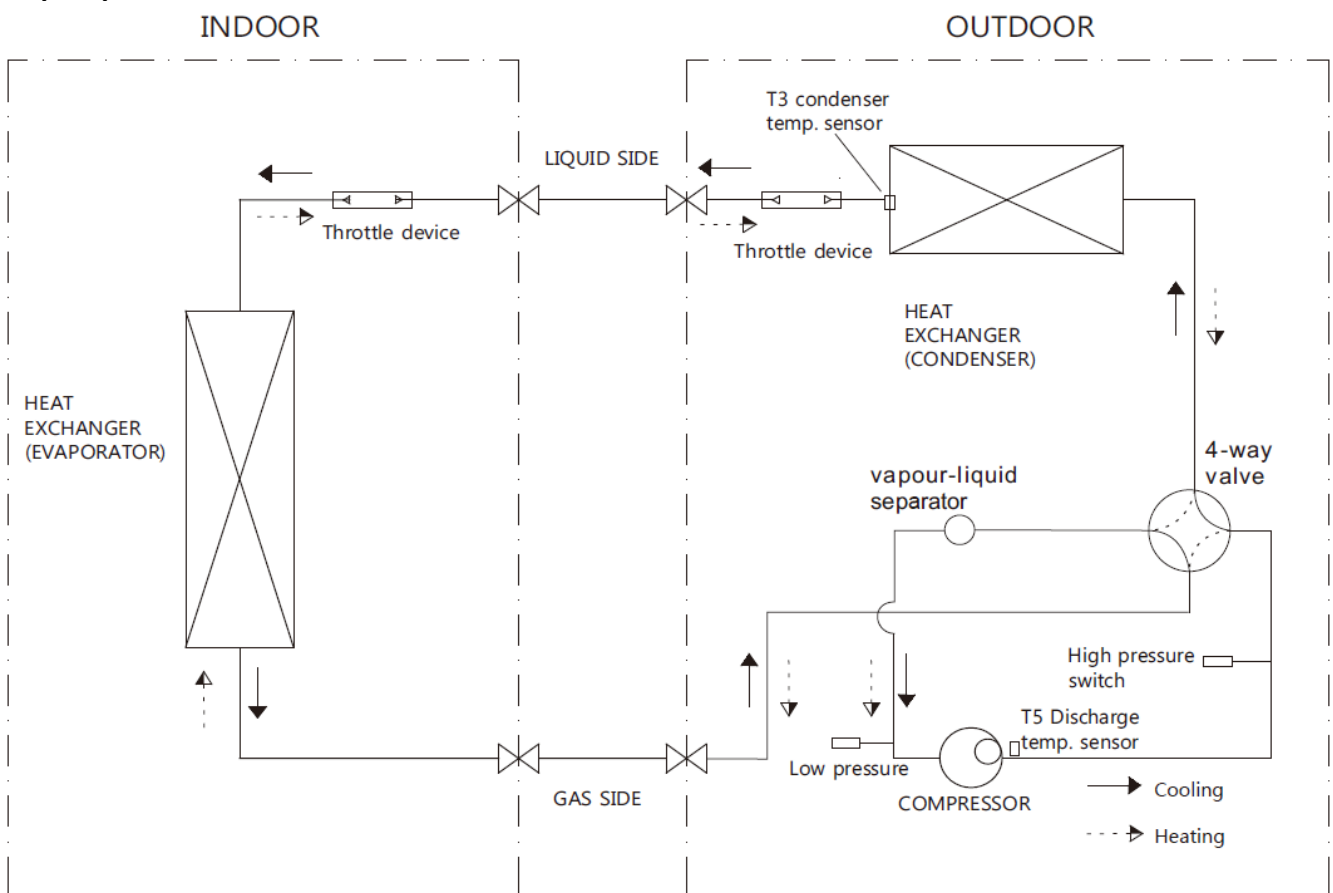

5. Wiring Diagrams

5.1 Outdoor Units

Cooling only models 18K-60K:

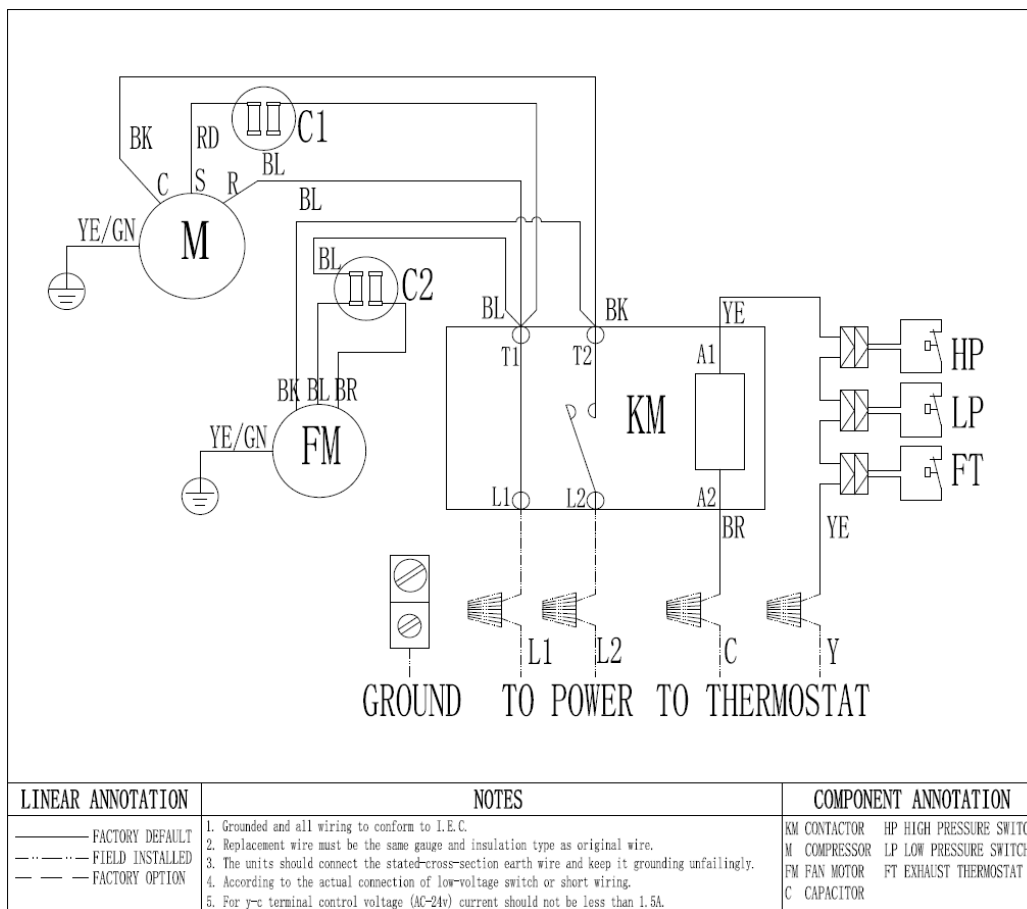

Heat pump models 18K-48K:

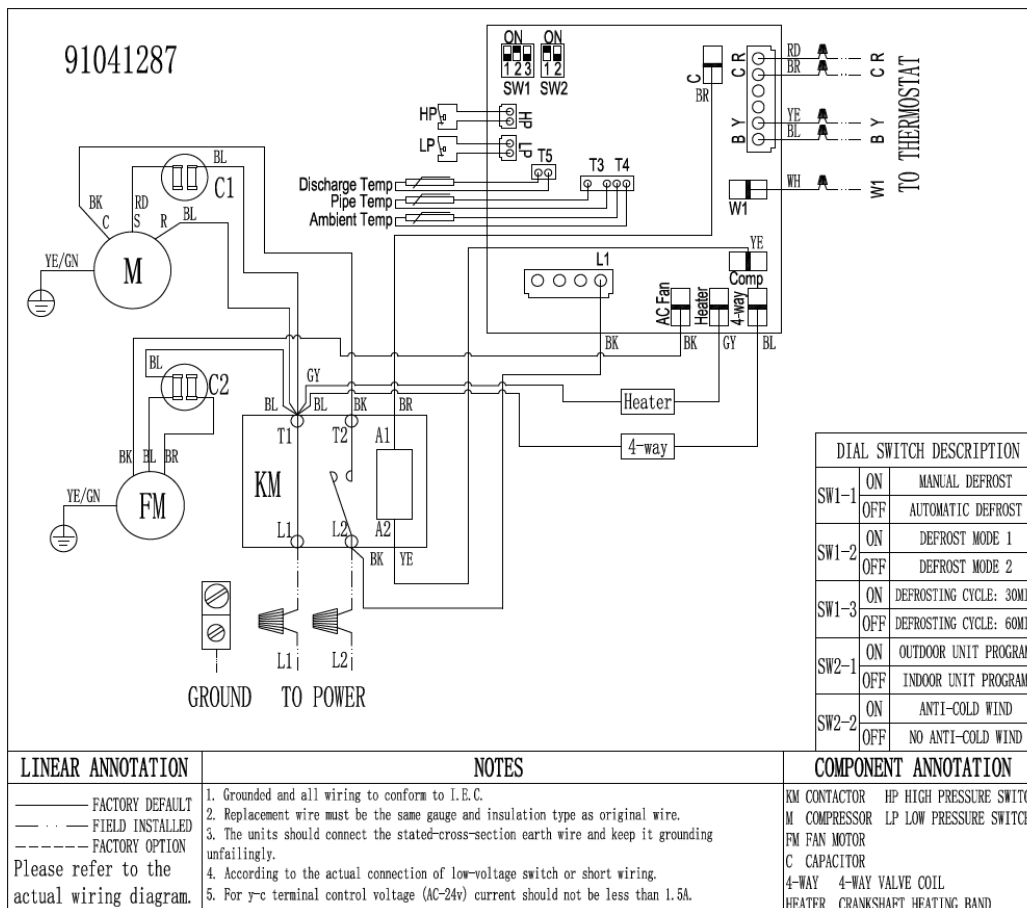

Heat pump models 60K:

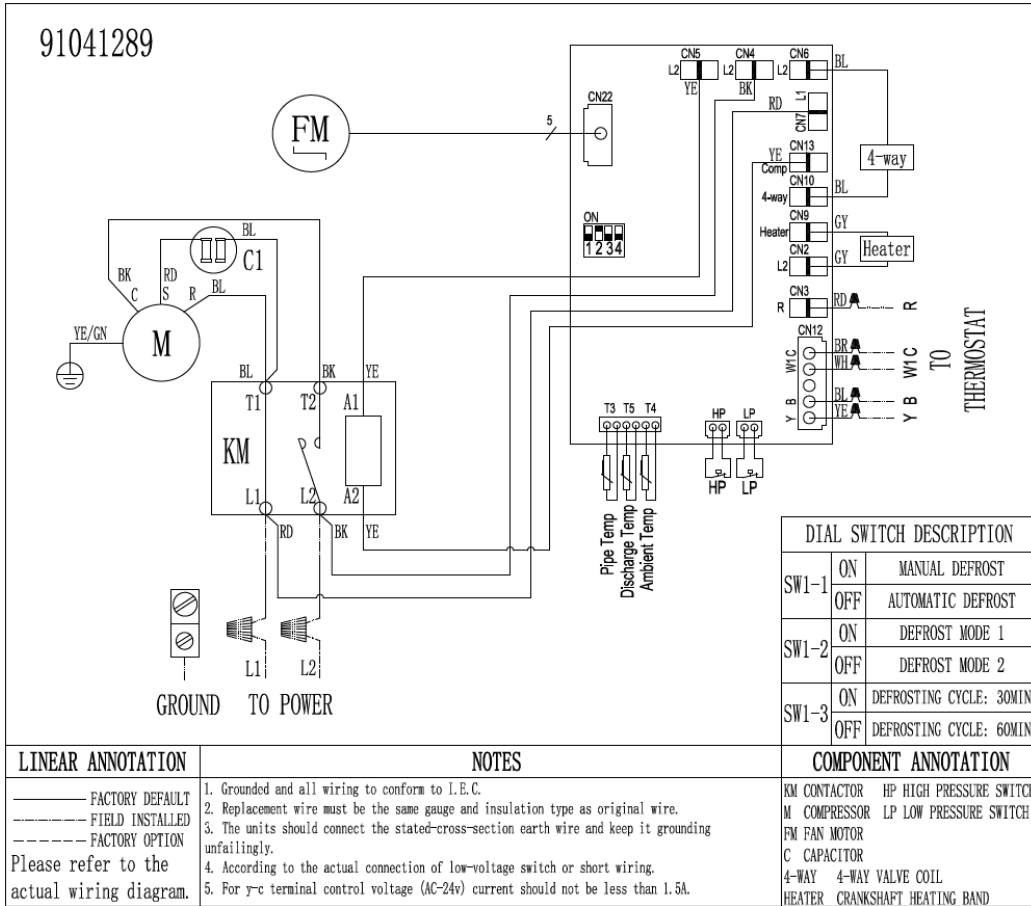

5.2 Indoor Units
Regular Air Handler:
18K, 24K:

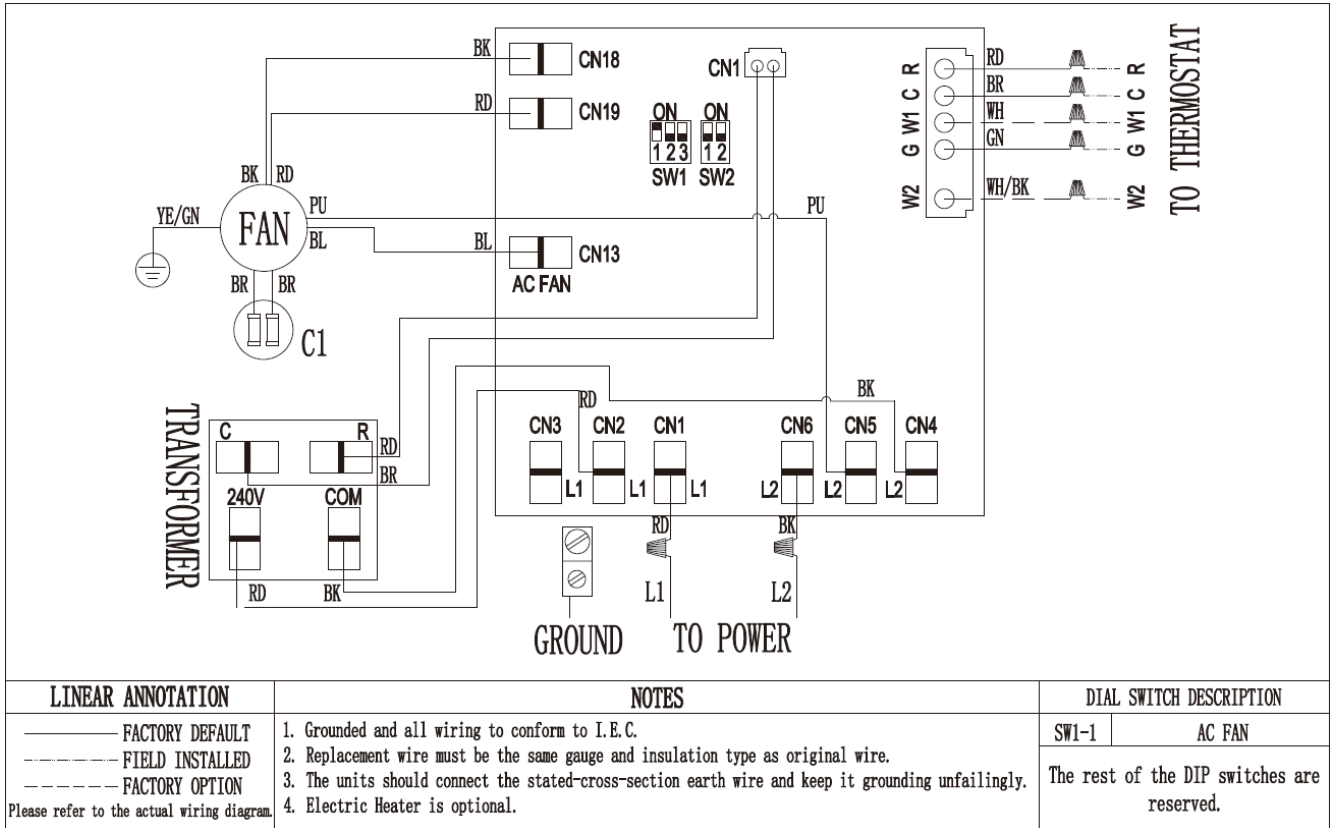

30K, 36K, 42K, 48K, 60K:

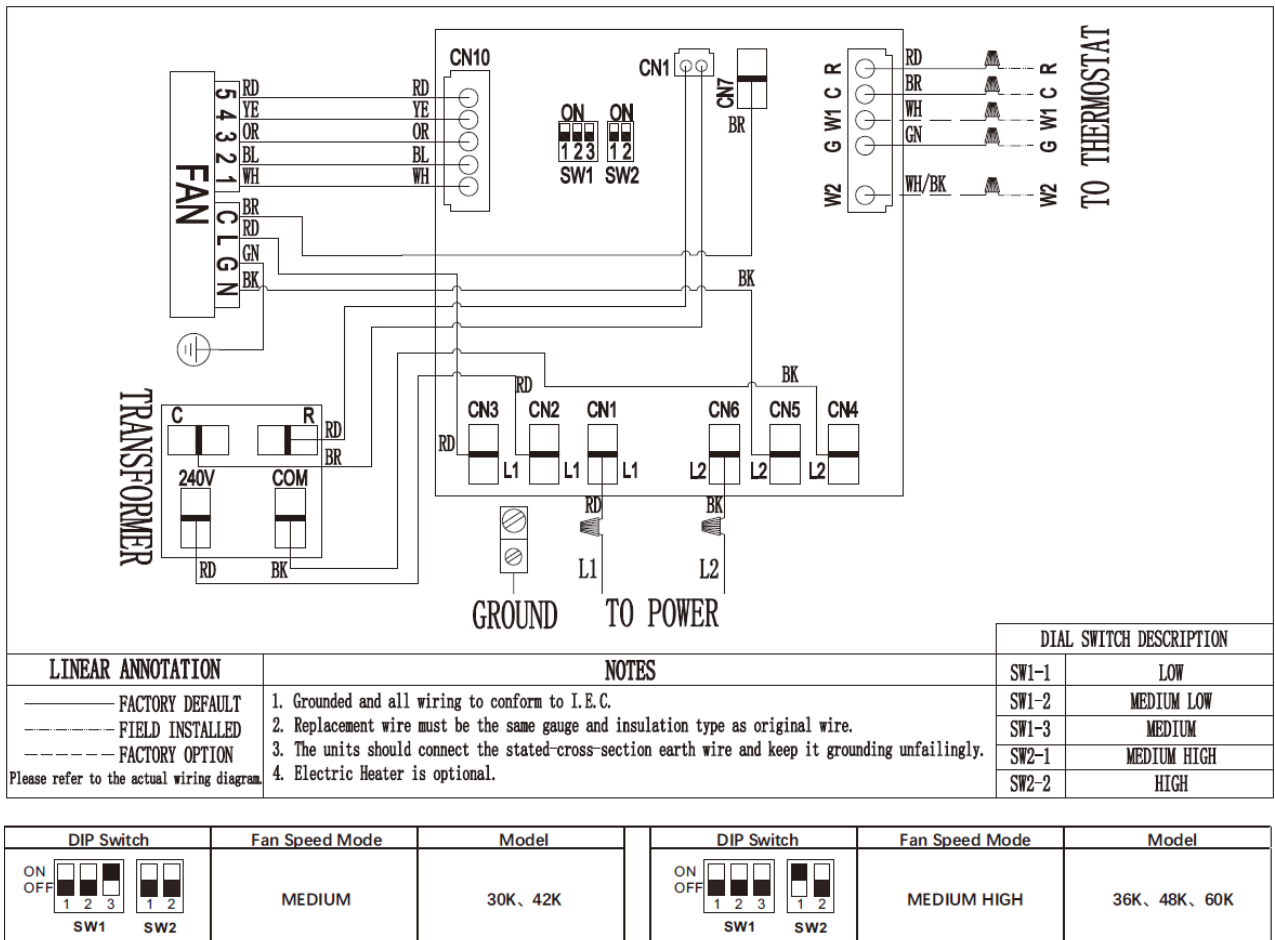

**Front Return Air Handler:
18K, 24K, 30K, 36K:**

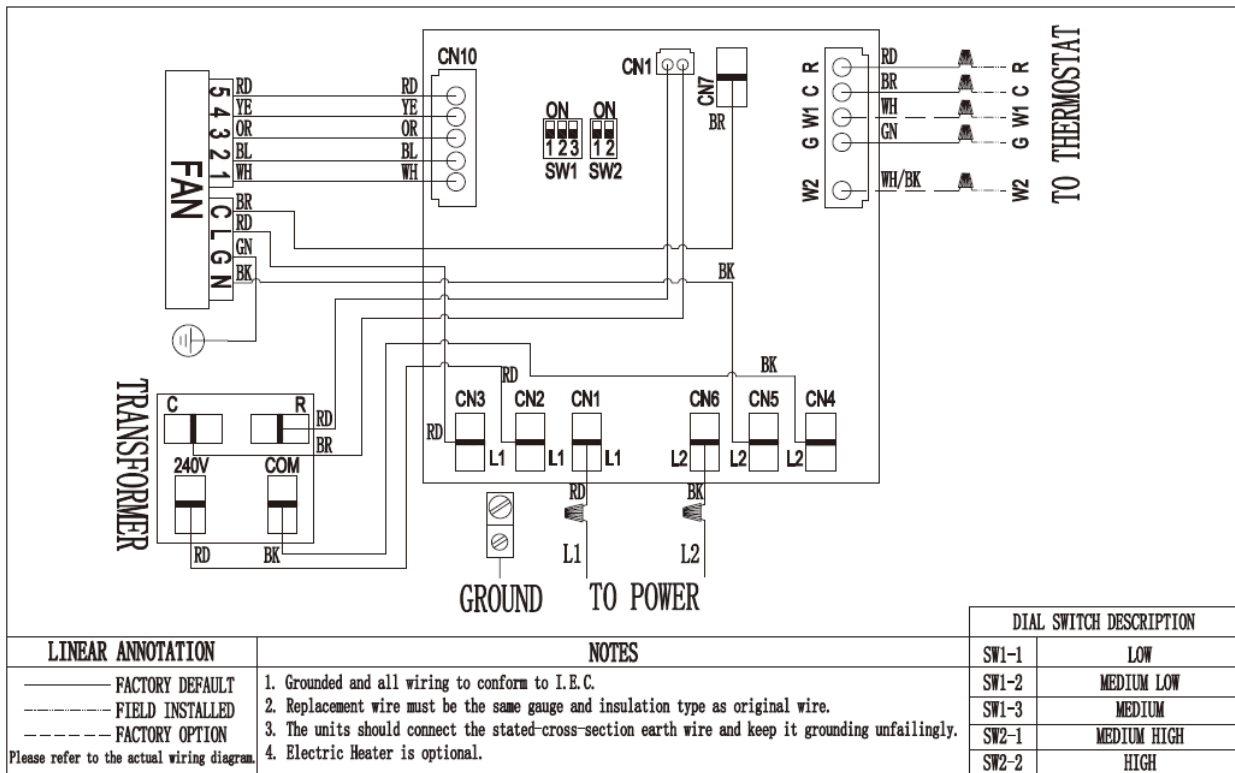

LINEAR ANNOTATION
 _____ FACTORY DEFAULT
 - - - - - FIELD INSTALLED
 - - - - - FACTORY OPTION
 Please refer to the actual wiring diagram.

NOTES
 1. Grounded and all wiring to conform to I.E.C.
 2. Replacement wire must be the same gauge and insulation type as original wire.
 3. The units should connect the stated-cross-section earth wire and keep it grounding unfliningly.
 4. Electric Heater is optional.

DIP Switch	Fan Speed Mode	Model	DIP Switch	Fan Speed Mode	Model
ON OFF SW1 SW2	MEDIUM LOW	18K	ON OFF SW1 SW2	MEDIUM HIGH	36K
ON OFF SW1 SW2	MEDIUM	24K, 30K	ON OFF SW1 SW2	HIGH	/

6. Capacity Tables

6.1 Cooling Capacity Tables

ATSCV4C4T18 ATSCV4H4T18 ATSEM4H4T18 - Orifice Conditions: 80 °F IDB, 67 °F IWB @ 580 CFM				
Outdoor Tem. °F.	Total Btu/h	Sensible Btu/h	Latent Btu/h	Total Watts
75	20909	14491	6417	1273
80	20371	14511	5861	1344
85	19816	14496	5320	1416
90	19243	14447	4796	1490
95	18650	14360	4289	1562
100	18107	14350	3757	1645
105	17548	14301	3246	1729
110	16972	14214	2758	1817
115	16378	14085	2293	1900

ATSCV4C4T24 ATSCV4H4T24 ATSEM4H4T24 - Orifice Conditions: 80 °F IDB, 67 °F IWB @ 800CFM				
Outdoor Tem. °F.	Total Btu/h	Sensible Btu/h	Latent Btu/h	Total Watts
75	27084	18742	8342	1656
80	26359	18557	7802	1737
85	25649	18442	7207	1829
90	24949	18337	6611	1920
95	24252	18311	5942	2024
100	23489	18321	5168	2114
105	22734	18301	4433	2218
110	21988	18250	3738	2331
115	21247	18060	3187	2454

ATSCV4C4T30 ATSCV4H4T30 ATSEM4H4T30- Orifice Conditions: 80 °F IDB, 67 °F IWB @ 980 CFM				
Outdoor Tem. °F.	Total Btu/h	Sensible Btu/h	Latent Btu/h	Total Watts
75	31475	22473	9002	1912
80	30844	22424	8421	2006
85	30173	22389	7785	2113
90	29464	22334	7130	2223
95	28726	22262	6463	2342
100	27930	22205	5726	2465
105	27093	22162	4931	2593
110	26228	21901	4328	2730
115	25338	21791	3547	2874

ATSCV4C4T36 ATSCV4H4T36 ATSEM4H4T36 - Orifice Conditions: 80 °F IDB, 67 °F IWB @ 1150CFM				
Outdoor Tem. °F.	Total Btu/h	Sensible Btu/h	Latent Btu/h	Total Watts
75	37813	26847	10966	2262
80	36925	26734	10191	2379
85	35982	26699	9283	2500
90	35023	26617	8406	2624
95	34059	26566	7493	2756
100	32946	26456	6490	2891
105	31851	26373	5478	3039
110	30774	26250	4524	3202
115	29721	26154	3566	3384

ATSCV4C4T42 ATSCV4H4T42 ATSEM4H4T42 - Orifice Conditions: 80 °F IDB, 67 °F IWB @ 1280 CFM				
Outdoor Tem. °F.	Total Btu/h	Sensible Btu/h	Latent Btu/h	Total Watts
75	45541	31332	14209	2803
80	44617	31187	13430	2954
85	43638	31070	12568	3112
90	42602	30887	11716	3274
95	41497	30708	10789	3444
100	40327	30648	9678	3604
105	39077	30558	8519	3771
110	37779	30412	7367	3945
115	36448	30361	6087	4126

ATSCV4C4T48 ATSCV4H4T48 ATSEM4H4T48- Orifice Conditions: 80 °F IDB, 67 °F IWB @ 1580CFM				
Outdoor Tem. °F.	Total Btu/h	Sensible Btu/h	Latent Btu/h	Total Watts
75	50471	35834	14637	3117
80	49380	35751	13629	3310
85	48231	35739	12492	3504
90	47090	35694	11396	3693
95	45997	35648	10349	3884
100	44944	35551	9393	4062
105	43803	35481	8323	4251
110	42577	35424	7153	4454
115	41280	35294	5986	4667

ATSCV4C4T60 ATSEM4H4T60- Orifice Conditions: 80 °F IDB, 67 °F IWB @ 1570 CFM				
Outdoor Tem. °F.	Total Btu/h	Sensible Btu/h	Latent Btu/h	Total Watts
75	61905	40424	21481	4039
80	60466	40331	20135	4241
85	58991	40232	18759	4450
90	57486	40068	17418	4673
95	56267	39950	16318	4911
100	54306	39860	14445	5141
105	52669	39818	12851	5388
110	51020	39693	11326	5653
115	49364	39590	9774	5933

ATSCI4H4T60 ATSEM4H4T60 - Orifice Conditions: 80 °F IDB, 67 °F IWB @ 1570CFM				
Outdoor Tem. °F.	Total Btu/h	Sensible Btu/h	Latent Btu/h	Total Watts
75	63127	40907	22221	3906
80	61698	40782	20915	4114
85	59352	40656	18696	4335
90	58246	40655	17590	4561
95	57175	40594	16581	4802
100	55459	40541	14919	5024
105	53886	40522	13364	5256
110	52304	40431	11873	5500
115	50719	40321	10397	5757

ATSCV4C4T18 ATSCV4H4T18 ATSEFR4H4T18- Orifice Conditions: 80 °F IDB, 67 °F IWB @ 715 CFM				
Outdoor Tem. °F.	Total Btu/h	Sensible Btu/h	Latent Btu/h	Total Watts
75	21772	15860	5912	1268
80	21041	15651	5390	1339
85	20296	15409	4887	1411
90	19536	15133	4403	1485
95	18759	14820	3939	1509
100	18188	14778	3410	1641
105	17601	14697	2904	1726
110	16998	14576	2422	1815
115	16378	14412	1965	1839

ATSCV4C4T24
 ATSCV4H4T24
 ATFR4H4T24 - Orifice
 Conditions: 80 °F IDB, 67 °F IWB @ 805CFM

Outdoor Tem. °F.	Total Btu/h	Sensible Btu/h	Latent Btu/h	Total Watts
75	27084	18742	8342	1636
80	26359	18557	7802	1720
85	25649	18442	7207	1809
90	24949	18337	6611	1900
95	24154	18336	5818	1996
100	23489	18321	5168	2089
105	22734	18301	4433	2190
110	21988	18250	3738	2300
115	21247	18060	3187	2419

ATSCV4C4T30
 ATSCV4H4T30
 ATFR4H4T30 - Orifice
 Conditions: 80 °F IDB, 67 °F IWB @ 1020 CFM

Outdoor Tem. °F.	Total Btu/h	Sensible Btu/h	Latent Btu/h	Total Watts
75	32019	23054	8965	1949
80	31334	22937	8398	2042
85	30475	22856	7619	2158
90	29578	22805	6773	2265
95	28661	22642	6019	2373
100	27895	22539	5356	2496
105	27095	22434	4660	2616
110	26242	22385	3858	2744
115	25372	22327	3045	2877

ATSCV4C4T36
 ATSCV4H4T36
 ATFR4H4T36- Orifice
 Conditions: 80 °F IDB, 67 °F IWB @ 1145CFM

Outdoor Tem. °F.	Total Btu/h	Sensible Btu/h	Latent Btu/h	Total Watts
75	37369	26532	10837	2273
80	36584	26523	10061	2392
85	35573	26395	9178	2510
90	34511	26229	8283	2638
95	33632	26233	7399	2775
100	32639	26046	6593	2911
105	31612	25922	5690	3059
110	30569	25831	4738	3422
115	29516	25679	3837	3404

7. Accessories

7.1 Standard Accessories

Items	Quantity
Installation manual	1
Drain pipe	1
Drain plug	2

7.2 Optional Accessories

Items	Accessories
a	Electric heater

Part 3

Outdoor Unit Installation

1. Safety	27
2. Unit Location Considerations	29
3. Unit Preparation	31
4. Setting the Unit	31
5. Refrigerant Line Considerations	32
6. Refrigerant Line Routing	33
7. Refrigerant Line Brazing	34
8. Refrigerant Line Leakage Check	36
9. Vacuum Drying	36
10. Service Valves	37
11. Additional Refrigerant Charge	37
12. Electrical Wiring	38

1. Safety

Important - This document contains a wiring diagram and service information. This is customer property and is to remain with this unit. Please return to service information pack upon completion of work.

CAUTION



This information is intended for use by individuals possessing adequate backgrounds of electrical and mechanical experience. Any attempt to repair a central air conditioning product may result in personal injury and/or property damage. The manufacturer or seller cannot be responsible for the interpretation of this information, nor can it assume any liability in connection with its use.

WARNING



HAZARDOUS VOLTAGE!

Failure to follow this warning could result in property damage, severe personal injury, or death. Disconnect all electric power, including remote disconnects before servicing. Follow proper lockout/tagout procedures to ensure the power cannot be inadvertently energized.

WARNING



REFRIGERANT OIL!

Any attempt to repair a central air conditioning product may result in property damage, severe personal injury, or death. These units use R-410A refrigerant which operates at 50 to 70% higher pressures than R-22. Use only R-410A approved service equipment. Refrigerant cylinders are painted a "Rose" color to indicate the type of refrigerant and may contain a "dip" tube to allow for charging of liquid refrigerant into the system. All R-410A systems with fixed speed compressors use a POE oil that readily absorbs moisture from the atmosphere to limit this 'hygroscopic' action. The system should remain sealed whenever possible. If a system has been open to the atmosphere for more than 4 hours, the compressor oil must be replaced. Never break a vacuum with air and always change the driers when opening the system for component replacement.

CAUTION



HOT SURFACE!

May cause minor to severe burning. Failure to follow this Caution could result in property damage or personal injury. Do not touch top of compressor.

CAUTION



CONTAINS REFRIGERANT!

Failure to follow proper procedures can result in personal illness or injury or severe equipment damage. System contains oil and refrigerant under high pressure. Recover refrigerant to relieve pressure before opening system.

CAUTION



GROUNDING REQUIRED!

Failure to inspect or use proper service tools may result in equipment damage or personal injury. Reconnect all grounding devices. All parts of this product that are capable of conducting electrical current are grounded. If grounding wires, screws, straps, clips, nuts, or washers used to complete a path to ground are removed for service, they must be returned to their original position and properly fastened.

WARNING**SERVICE VALVES!**

Failure to follow this warning will result in abrupt release of system charge and may result in personal injury and/or property damage. Extreme caution should be exercised when opening the Liquid Line Service valve. Turn valve stem counterclockwise only until the stem contacts the rolled edge. No torque is required.

WARNING**BRAZING REQUIRED!**

Failure to inspect lines or use proper service tools may result in equipment damage or personal injury. If using existing refrigerant lines make certain that all joints are brazed, not soldered.

WARNING**HIGH LEAKAGE CURRENT!**

Failure to follow this warning could result in property damage, severe personal injury, or death. Earth connection essential before connecting electrical supply.

2. Unit Location Considerations

2.1 Unit Dimensions and Location Restrictions

When mounting the outdoor unit on a roof, be sure the roof will support the unit's weight. Properly selected isolation is recommended to prevent sound or vibration transmission to the building structure.

- Ensure the top discharge area is unrestricted for at least 60 inches above the unit.
- Clearance must be provided in front of the control box (access panels) and any other side requiring service.
- Position the outdoor unit a minimum of 18 inches from any wall or surrounding shrubbery to ensure adequate airflow.
- Outdoor unit location must be far enough away from any structure to prevent excess roof runoff water from pouring directly on the unit.

Note: It is recommended that these precautions be taken for units being installed in areas where snow accumulation and prolonged below-freezing temperatures occur.

- Units should be elevated 3-12 inches above the pad or rooftop, depending on local weather. This additional height will allow drainage of snow and ice melted during defrost cycle prior to its refreezing. Ensure that drain holes in unit base pan are not obstructed, preventing drainage of defrost water.
- If possible, avoid locations that are likely to accumulate snow drifts. If not possible, a snow drift barrier should be installed around the unit to prevent a build-up of snow on the sides of the unit.

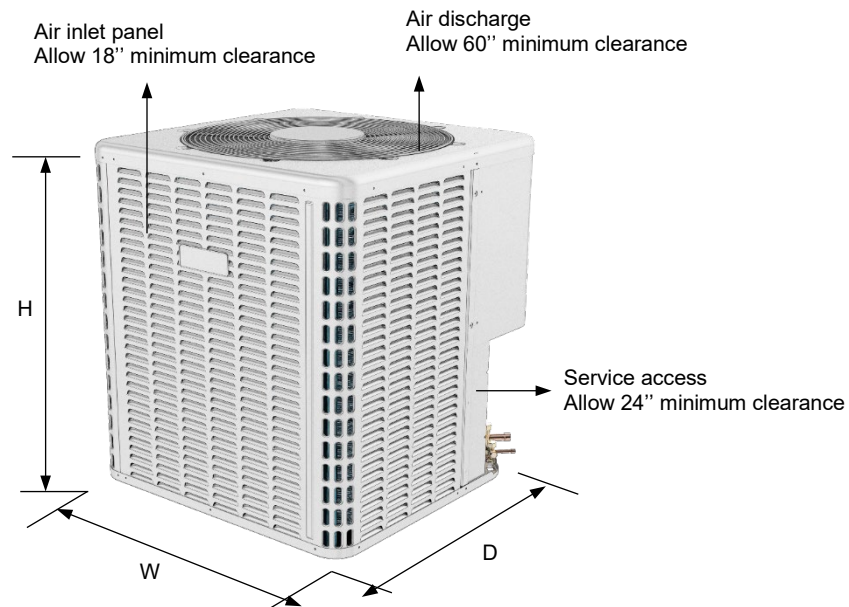

Model	Dimensions			Refrigerant Connection Service Valve Size	
	"W" mm (in.)	"D" mm (in.)	"H" mm (in.)	Liquid (in.)	Gas (in.)
18K	600 (23-5/8)	600 (23-5/8)	635 (25)	3/8	3/4
24K				3/8	3/4
30K				3/8	3/4
36K	740 (29-1/8)	740 (29-1/8)	635 (25)	3/8	3/4
42K	740 (29-1/8)	740 (29-1/8)	835 (32-7/8)	3/8	3/4
48K				3/8	7/8
60K				3/8	7/8

2.2 Refrigerant Piping Limits

Considering the allowable pipe length and height drop to determine the installation position. Make sure the distance and height drop between indoor and outdoor unit not exceed the data in the following table.

Model	Max. length ft(m)	Max. height drop ft(m)	Max. bend (pcs)
18-60 kBtu/h	148(45)	66(20)	5

2.3 Service Space

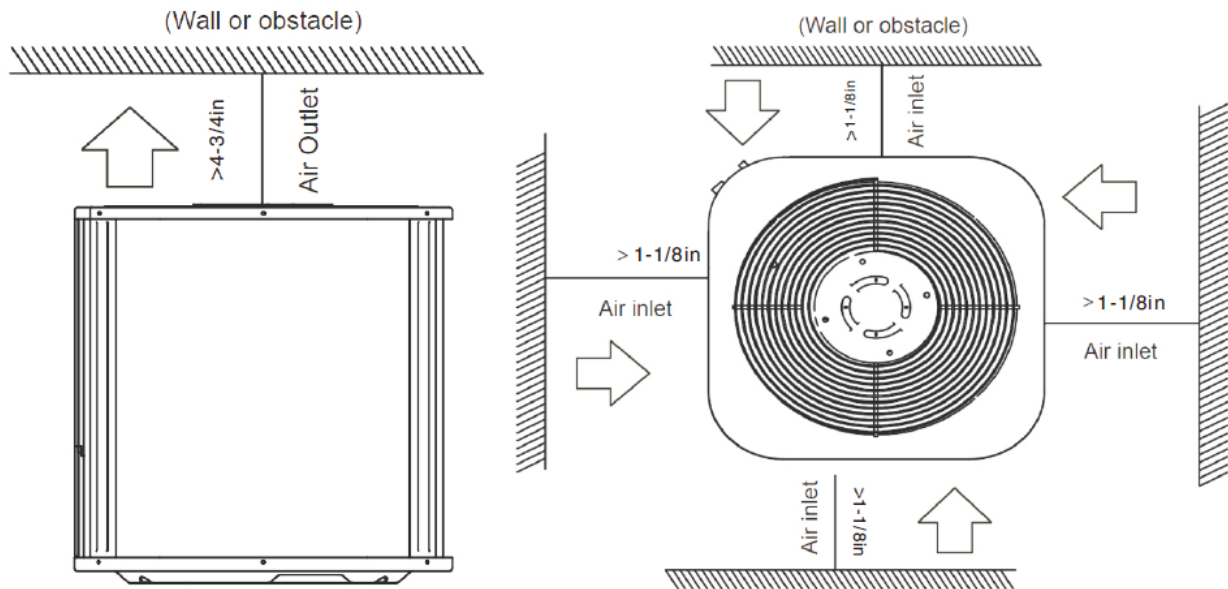

3. Unit Preparation

Check for damage and report promptly to the carrier any damage found to the unit.

The charge port can be used to check to be sure the refrigerant charge has been retained during shipment.

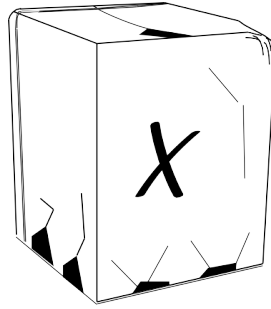

4. Setting the Unit

When installing the unit on a support pad, such as a concrete slab, consider the following:

- The pad should be at least 1-2" larger than the unit on all sides.
- The pad must be separate from any structure.
- The pad must be level.
- The pad should be high enough above grade to allow for drainage.
- The pad location must comply with National, State, and Local codes.

IMPORTANT NOTE: These instructions are intended to provide a method to tie-down system to cement slab as a securing procedure for high wind areas. It is recommended to check Local Codes for tie-down methods and protocols.

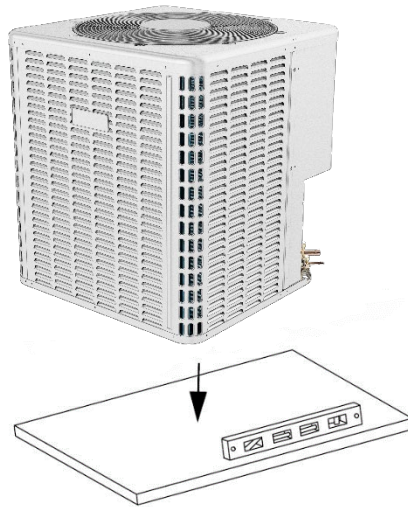

5. Refrigerant Line Considerations

5.1 Refrigerant Line and Service Valve Connection Sizes

Model	Line Sizes		Service Valve Connection Sizes	
	Suction Line	Liquid Line	Suction Line Connection	Liquid Line Connection
18K/24K/30K/36K/42K	3/4	3/8	3/4	3/8
48K/60K	7/8	3/8	7/8	3/8

5.2 Refrigerant Line Length and Insulation

Determine required line length.

IMPORTANT: The Suction Line must always be insulated. DO NOT allow the Liquid Line and Suction Line to come in direct (metal to metal) contact.

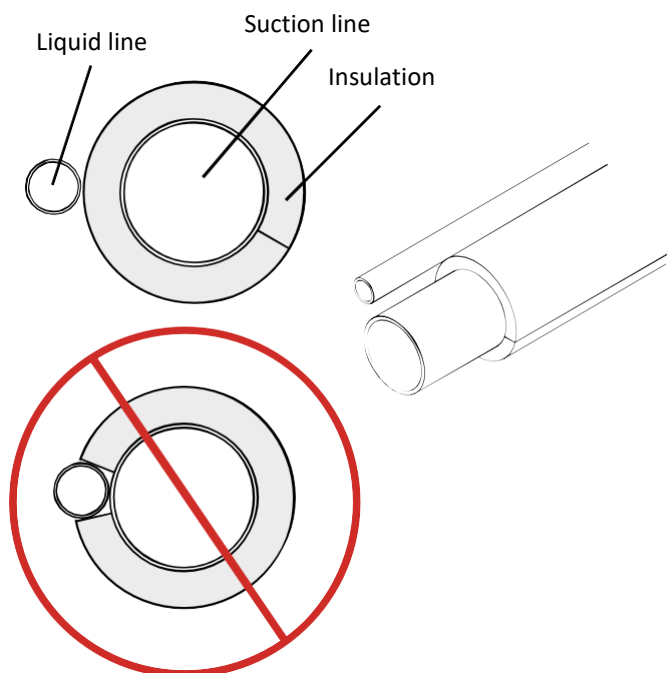

5.3 Reuse Existing Refrigerant Lines

CAUTION



If using existing refrigerant lines make certain that all joints are brazed, not soldered.

For retrofit applications, where the existing refrigerant lines will be used, the following precautions should be taken:

- Ensure that the refrigerant lines are the correct size.
- Ensure that the refrigerant lines are free of leaks, acid, and oil.

Note: The manufacturer recommends installing only approved matched indoor and outdoor systems. Some of the benefits of installing approved matched indoor and outdoor split systems are maximum efficiency, optimum performance and the best overall system reliability.

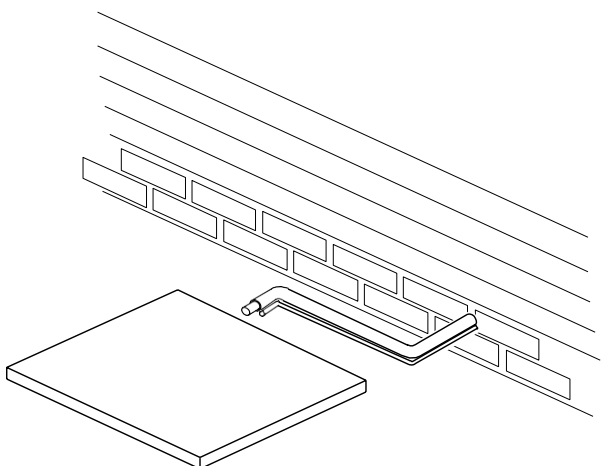

6. Refrigerant Line Routing

Important: Take precautions to prevent noise within the building structure due to vibration transmission from the refrigerant lines.

Comply with National, State, and Local Codes when isolating line sets from joists, rafters, walls, or other structural elements.

For Example:

- When the refrigerant lines have to be fastened to floor joists or other framing in a structure, use isolation type hangers.
- Isolation hangers should also be used when refrigerant lines are run in stud spaces or enclosed ceilings.
- Where the refrigerant lines run through a wall or sill, they should be insulated and isolated.
- Isolate the lines from all ductwork.
- Minimize the number of 90° turns.

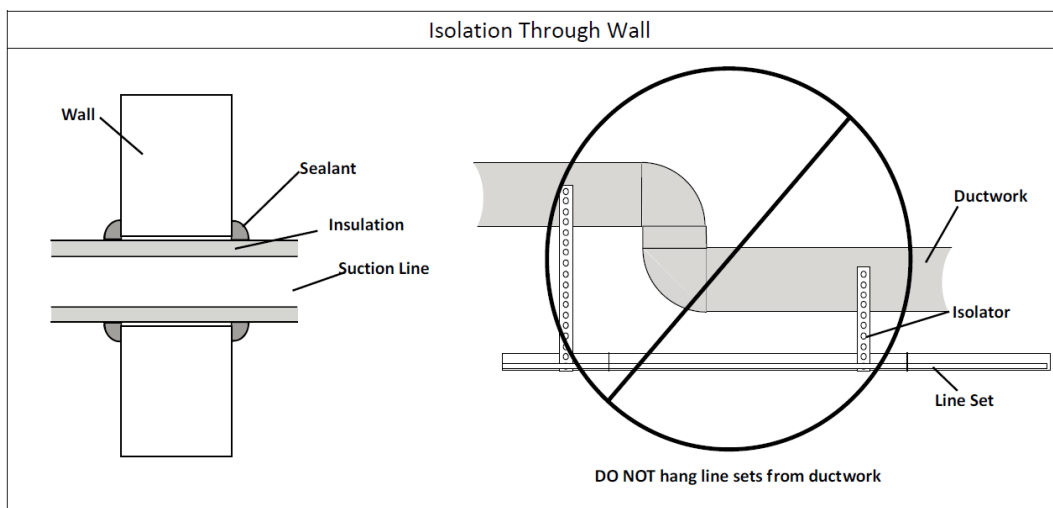
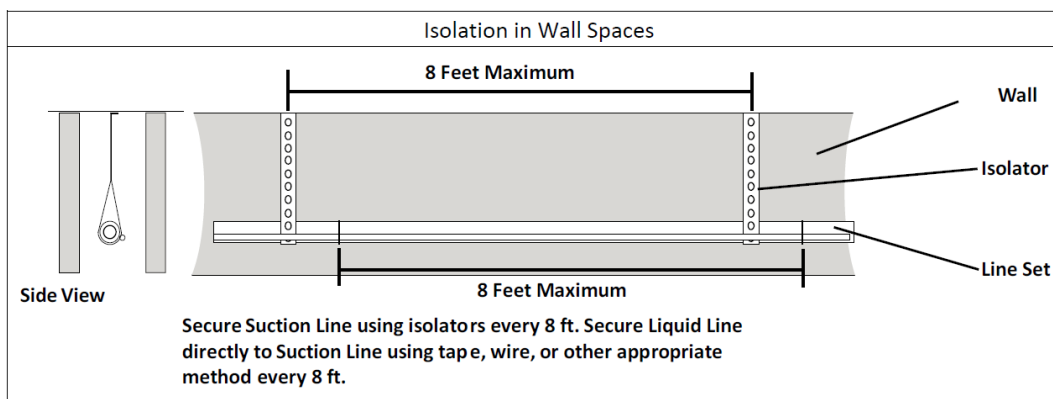
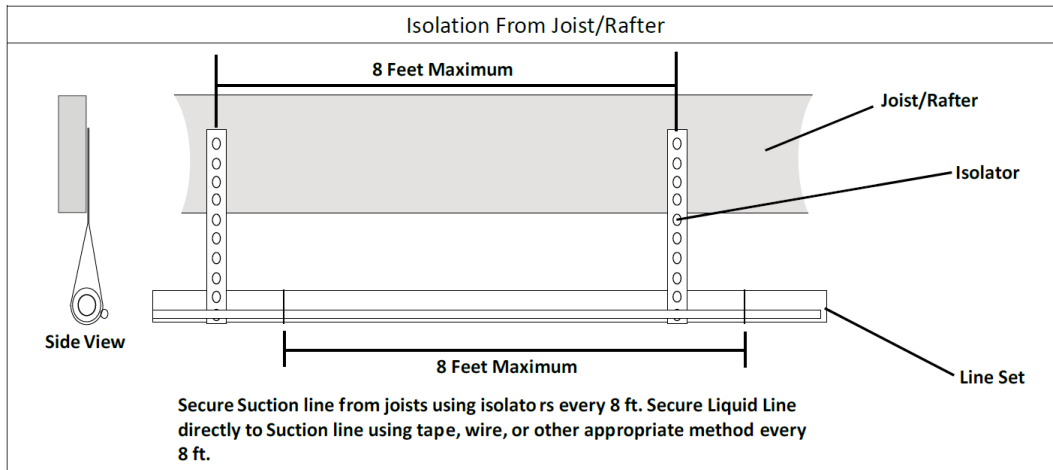

7. Refrigerant Line Brazing

1. Remove caps or plugs. Use a deburring tool to deburr the pipe ends. Clean both internal and external surfaces of the tubing using an emery cloth.

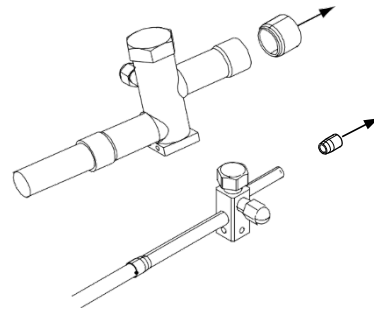

2. Remove the pressure tap cap from both service valves.

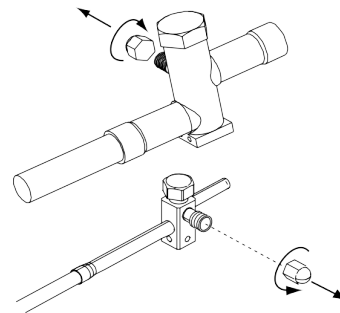

3. Purge the refrigerant lines and indoor coil with dry nitrogen.

This pipe must have a thimble.

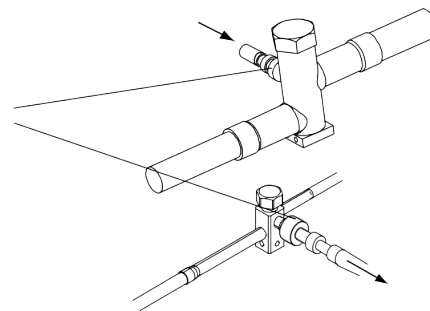

4. Wrap a wet rag around the valve body to avoid heat damage and continue the dry nitrogen purge.

Braze the refrigerant lines to the service valves.

Check liquid line filter drier's directional flow arrow to confirm correct direction of refrigeration flow (away from outdoor unit and toward evaporator coil) as illustrated. Braze the filter drier to the Liquid Line.

Continue the dry nitrogen purge. Do not remove the wet rag until all brazing is completed.

Important: Remove the wet rag before stopping the dry nitrogen purge.

Note: Install drier in Liquid Line.

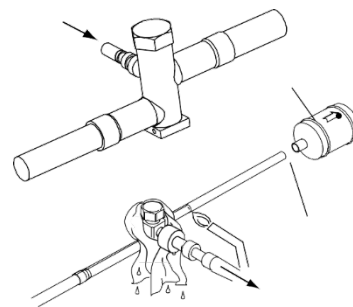

5. Replace the pressure tap caps after the service valves have cooled.

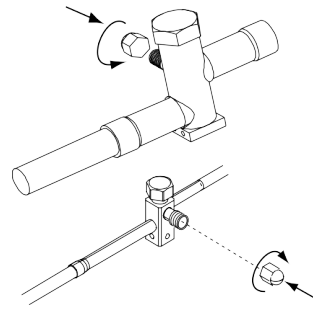

8. Refrigerant Line Leakage Check

Pressurize the refrigerant lines and evaporator coil to 150 PSIG using dry nitrogen.

Check for leaks by using a soapy solution or bubbles at each brazed location.

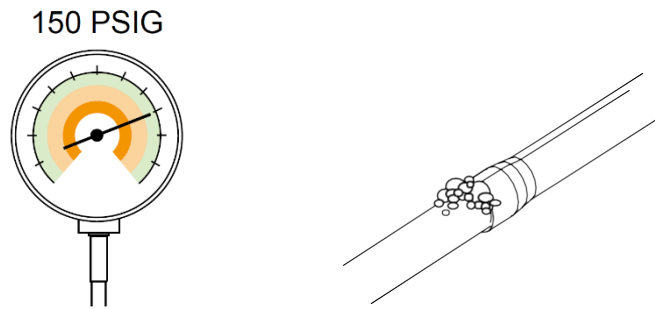

9. Vacuum Drying

Eliminating moisture in system to prevent the phenomena of ice-blockage and copper oxidation. Ice-blockage shall cause abnormal operation of system, while copper oxide shall damage compressor.

Eliminating the non-condensable gas (air) in system to prevent the components oxidizing, pressure fluctuation and bad heat exchange during the operation of system.

The ultimate vacuum degree of vacuum pump shall be -756mmHg or above. Precision of vacuum pump shall reach 0.02mmHg or above.

10. Service Valves

WARNING



Extreme caution should be exercised when opening the Liquid Line Service Valve. Turn counterclockwise until the valve stem just touches the rolled edge. No torque is required. Failure to follow this warning will result in abrupt release of system charge and may result in personal injury and /or property damage.

Important: Leak check and evacuation must be completed before opening the service valves.

Important: The Suction Service Valve must be opened first BEFORE opening the Liquid Service Valve!

1. Remove service valve cap.
2. Fully insert hex wrench into the stem and back out counterclockwise until valve stem just touches the rolled edge.
3. Replace the valve stem cap to prevent leaks. Tighten finger tight plus an additional 1/6 turn.
4. Repeat STEPS 1 - 3 for Liquid Service Valve.

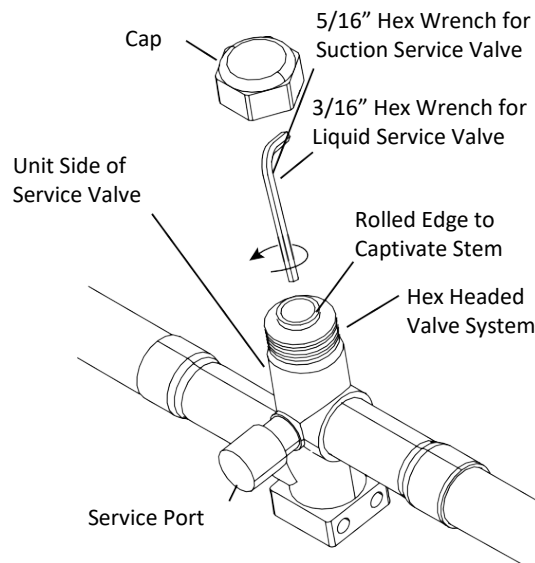

11. Additional Refrigerant Charge

After the vacuum drying process is carried out, the additional refrigerant charge process need to be performed.

The outdoor unit is factory charged with refrigerant. The additional refrigerant charge volume is determined by the diameter and length of the liquid pipe between indoor and outdoor unit. Refer the following formula to calculate the charging volume.

Diameter of liquid pipe inch (mm)	1/4 (6.35)	3/8 (9.52)	1/2 (12.7)
Formula	$V=0.22oz \times (L-16)$	$V=0.43oz \times (L-16)$	$V=0.64oz \times (L-16)$

V: Additional refrigerant charging volume (oz).

L: The length of liquid pipe (ft).

Charging: weigh-In Method

Weigh-In Method can be used for the Initial installation, or anytime a system charge is being replaced. weigh-In Method can also be used when power is not available to the equipment site or operating conditions (indoor/outdoor temperatures) are not in range to verify with the subcooling charging method.

12. Electrical Wiring

WARNING



LIVE ELECTRICAL COMPONENTS!

During installation, testing, servicing, and troubleshooting of this product, it may be necessary to work with live electrical components. Failure to follow all electrical safety precautions when exposed to live electrical components could result in death or serious injury.

The right table defines the maximum total length of low voltage wiring from the outdoor unit, to the indoor unit, and to the thermostat.

Field provided bushing or strain relief is required at the low voltage wire entry point.

24 VOLTS	
WIRE SIZE	MAX.WIRE LENGTH
18 AWG	150 Ft.
16 AWG	225 Ft.
14 AWG	300 Ft.

Notes:

1. Be sure power supply agrees with the equipment nameplate.
2. Power wiring and grounding of equipment must comply with national, state, and local codes.
3. Follow instructions on unit wiring diagram located on the inside of the control box cover.
4. Install a separate disconnect switch at the outdoor unit.
5. Field provided flexible electrical conduit must be used for high voltage wiring.

Part 4

Indoor Unit Installation

1. Safety	40
2. Applications.....	42
3. Electrical Wiring	45
4. Airflow Performance	47
5. Ductwork.....	49
6. Refrigerant Connections	50
7. Air Filter (not factory-installed)	52
8. Filter Installation Dimensions.....	53
9. Wiring Diagram.....	54
10. Electrical Wiring Gauge	55

1. Safety

Important - This is an attention alert symbol. When you see this symbol on labels or in manuals, be alert to the potential for personal injury.

WARNING



Disconnect all power to unit before installing or servicing. More than one disconnect switch may be required to de-energize the equipment. Hazardous voltage can cause severe personal injury or death.

WARNING



If removal of the blower assembly is required, all disconnect switches supplying power to the equipment must be de-energized and locked (if not in sight of unit) so the field power wires can be safely removed from the blower assembly. Failure to do so can cause electrical shock resulting in personal injury or death.

WARNING



Because of possible damage to equipment or personal injury, installation, service, and maintenance should be performed by a trained, qualified service personnel. Consumer service is recommended only for filter cleaning / replacement. Never operate the unit with the access panels removed.

WARNING



These instructions are intended as an aid to qualified, licensed service personnel for proper installation, adjustment and operation of this unit. Read these instructions thoroughly before attempting installation or operation. Failure to follow these instructions may result in improper installation, adjustment, service or maintenance possibly resulting in fire, electrical shock, property damage, personal injury or death.

WARNING



The unit must be permanently grounded. Failure to do so can result in electrical shock causing personal injury or death.

CAUTION



Make sure the blower motor support is tight (3-motor mount bolts) then check to see if wheel is secured to motor shaft before operating unit.

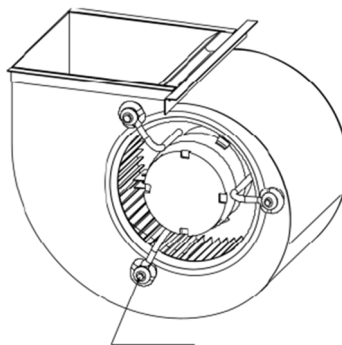

Blower motor shipping bolt

WARNING

PROPOSITION 65: This appliance contains fiberglass insulation. Respirable particles of fiberglass are known to State of California to cause cancer.

All manufacturer products meet current federal OSHA Guidelines for safety. California Proposition 65 warnings are required for certain products, which are not covered by the OSHA standards.

California's Proposition 65 requires warnings for products sold in California that contain or produce any of over 600 listed chemicals known to the State of California to cause cancer or birth defects such as fiberglass insulation, lead in brass, and combustion products from natural gas.

All "new equipment" shipped for sale in California will have labels stating that the product contains and /or produces Proposition 65 chemicals. Although we have not changed our processes, having the same label on all our products facilitates manufacturing and shipping. We cannot always know "when, or if" products will be sold in the California market.

You may receive inquiries from customers about chemicals found in, or produced by, some of our heating and air-conditioning equipment, or found in natural gas used with some of our products. Listed below are those chemicals and substances commonly associated with similar equipment in our industry and other manufacturers.

Glass Wool (Fiberglass) Insulation

Carbon Monoxide (CO).

Formaldehyde

Benzene

More details are available at the websites for OSHA (Occupational Safety and Health Administration), at www.osha.gov and the State of California's OEHHA (Office of Environmental Health Hazard Assessment), at www.oehha.org. Consumer education is important since the chemicals and substances on the list are found in our daily lives. Most consumers are aware that products present safety and health risks, when improperly used, handled and maintained.

WARNING

The first 6 inches of supply air plenum and ductwork must be constructed of sheet metal as required by NFPA 90B. The supply air plenum or duct must have a solid sheet metal bottom directly under the unit with no openings, registers or flexible air ducts located in it. If flexible supply air ducts are used they may be located only in the vertical walls of rectangular plenum, a minimum of 6 inches from the solid bottom. Metal plenum or duct may be connected to the combustible floor base, if not, it must be connected to the unit supply duct exposed to the supply air opening from the downflow unit.

Exposing combustible (non-metal) material to the supply opening of a downflow unit can cause a fire resulting in property damage, personal injury or death.

Exception warning to downflow:

Installation on concrete floor slab with supply air plenum and ductwork completely encased must be not less than 2 inches of concrete (See NFPA 90A).

2. Applications

Regular Air Handler:

2.1 Vertical Upflow

- Vertical Upflow configuration is the factory set on all models.
- If return air is to be ducted, install duct flush with floor.

Use fireproof resilient gasket 1/8 to 1/4 in. thick between the ducts, unit and floor. Set unit on floor over opening.

IMPORTANT NOTE

Torque applied to drain connections should not exceed 15.ft.lbs.

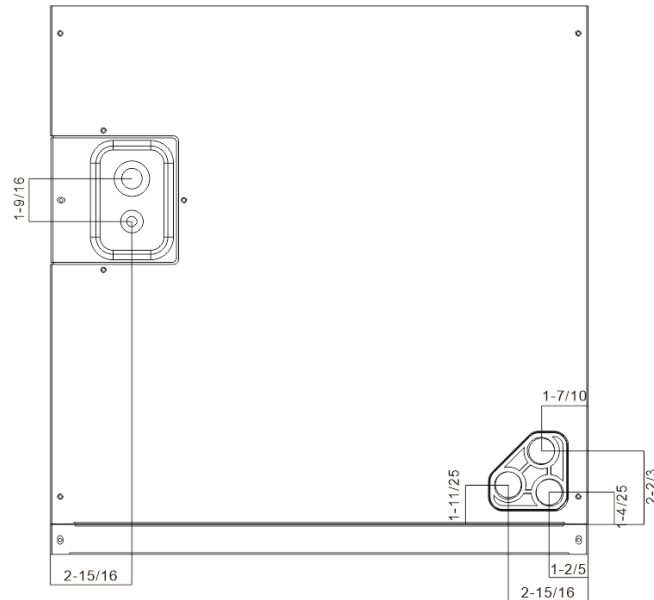

2.2 Vertical Downflow

Conversion to Vertical Downflow: A vertical upflow unit may be converted to vertical downflow. Remove the panel and indoor coil and reinstall 180° from original position.

2.3 Horizontal

Horizontal right is the default factory configuration for the units. Conversion to Horizontal left: A vertical upflow unit may be converted to horizontal left by removing indoor coil assembly and reinstalling coil as shown for left hand air supply.

- Rotate unit into the downflow position, with the coil compartment on top and the blower compartment on bottom.
- Reinstall the indoor coil 180° from original position. Ensure the retaining channel is fully engaged with the coil rail.
- Secondary drain pan kits are recommended when the unit is configured for the horizontal position over a finished ceiling and/or living space.

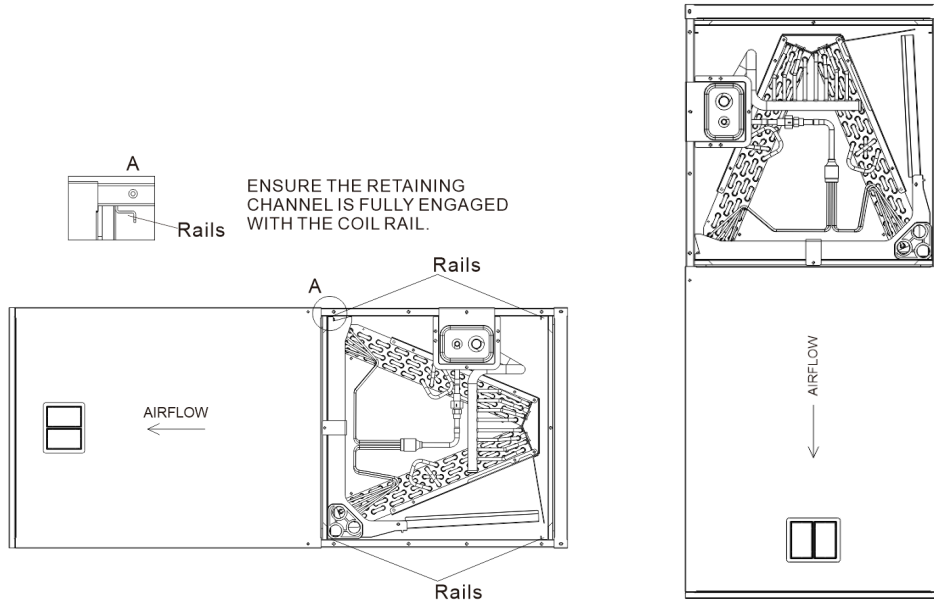

CAUTION



Horizontal units must be configured for right hand air supply or left hand air supply. Horizontal drain pan must be located under indoor coil. Failure to use the drain pan can result in property damage.

Front Return Air Handler:

2.4 Wall Mount

The air handler comes standard with a wall mounting bracket and air handler mounting bracket.

- Remove lower wall mounting bracket from the back of the unit by removing one screw which attaches the bracket to the air handler.

Note: Discard the screw after you have removed the wall mounting bracket.

- Install bracket on the wall by using 3 wood screws (not provided). Make sure the bracket is level in order to provided proper drainage from the unit.

Note: Do not attach the wall mounting bracket into unsupported dry wall. Make sure that the wood screws are going into a structure that can support a minimum load of 150 lb.

- Lift the air handler above the wall mounting bracket and attach the unit to the installed bracket.
- Install the additional bottom plate for extra support for this type mounting.

Note: The additional plate is shipped in the bottom of the shipping carton.

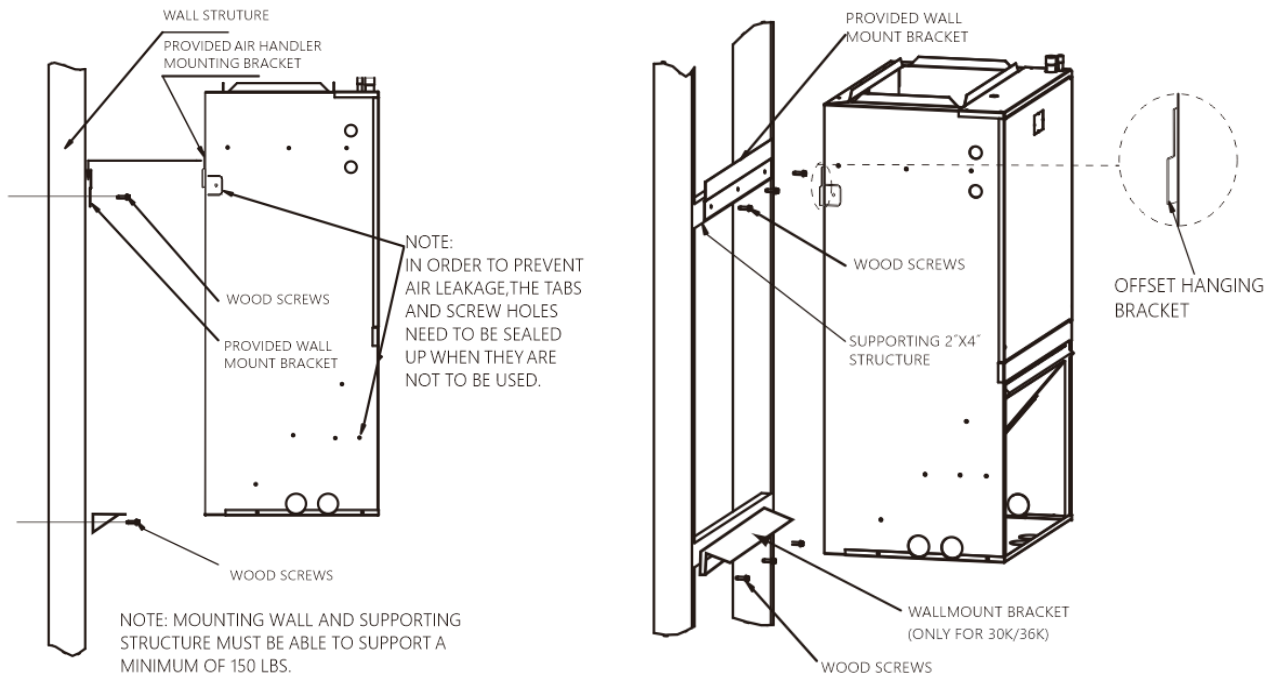

2.5 Frame Mount

The air handler comes with 8 clearance holes (4 on each side). These holes are used to mount the air handler inside of a frame structure. When mounting in this fashion, make sure that the wood screws are mounted from within the air handler and not from outside the unit in order to avoid damaging the coil. If the frame does not provide support in the front of the unit and additional support is needed, open up the tabs and fix the unit to the frame or other support structure with screws. Select a solid and level site to ensure proper installation of the frame mount. Verify that there is sufficient space for installation and maintenance.

IMPORTANT: The (8) wood screws are not provided with the unit. #12 x 1 1/2" wood screws are recommended. When the unit is installed on a wood frame, the screws should be used to fix the unit to the studs. If they are not used, the unit may fall down or cause other damage.

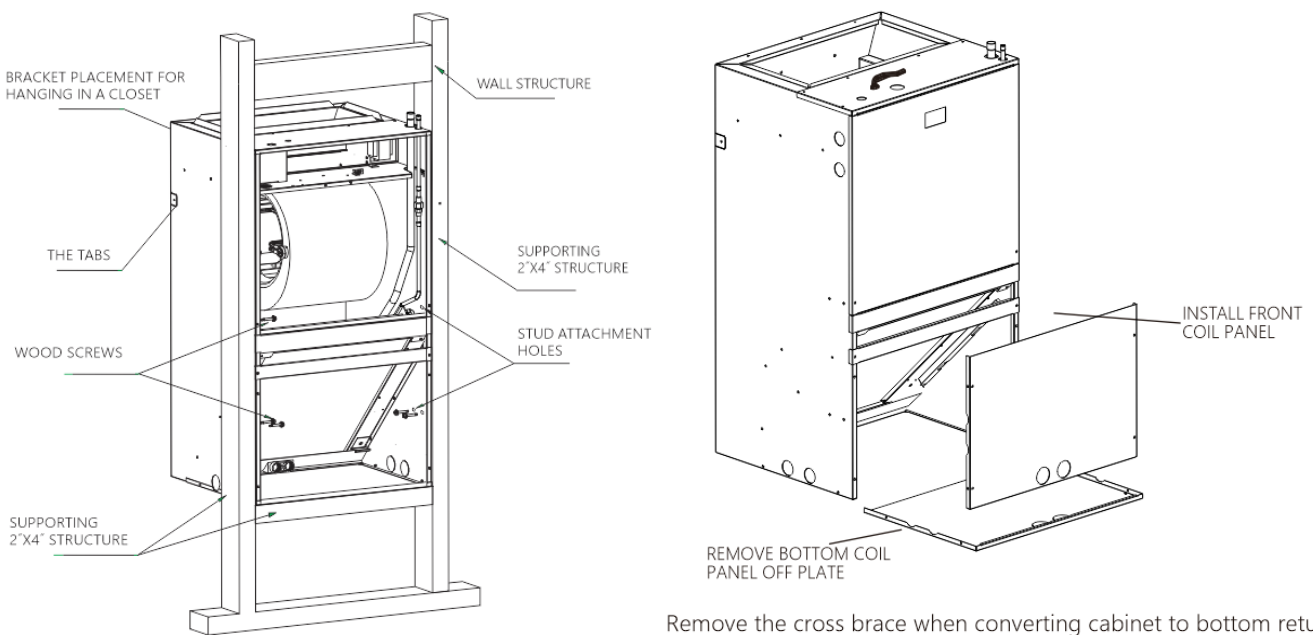

3. Electrical Wiring

Field wiring must comply with the National Electric Code and any applicable local ordinance.

WARNING



Disconnect all power to unit before installing or servicing. More than one disconnect switch may be required to de-energize the equipment. Hazardous voltage can cause severe personal injury or death.

3.1 Power Wiring

It is important that proper electrical power is available for connection to the unit model being installed. See the unit nameplate, wiring diagram and electrical data in the installation instructions.

- If required, install a branch circuit disconnect of adequate size, located within sight of, and readily accessible to the unit.
- **IMPORTANT:** After the Electric Heater is installed, units may be equipped with one or two 30-60 amp. circuit breakers. These breaker(s) protect the internal wiring in the event of a short circuit and serve as a disconnect. Circuit breakers installed within the unit do not provide over-current protection of the supply wiring and therefore may be sized larger than the branch circuit protection.
- Supply circuit power wiring must be 75°C minimum copper conductors only. See Electrical Data in this section for ampacity, wire size and circuit protector requirement. Supply circuit protective devices may be either fuses or “HACR” type circuit breakers.
- Power wiring may be connected to either the right, left side or top. Concentric knockouts are provided for connection of power wiring to unit.

3.2 Control Wiring

IMPORTANT: Class 2 low voltage control wiring should not be run in conduit with main power wiring and must be separated from power wiring, unless class 1 wire of proper voltage rating is used.

- Low voltage control wiring should be 18 Awg. color-coded. For lengths longer than 100 ft., 16 Awg. wire should be used.
- See wiring diagrams attached to indoor and outdoor sections to be connected.
- Make sure, after installation, separation of control wiring and power wiring has been maintained.

3.3 Grounding

WARNING



The unit must be permanently grounded. Failure to do so can result in electrical shock causing personal injury or death.

- Grounding may be accomplished by grounding metal conduit when installed in accordance with electrical codes to the unit cabinet.
- Grounding may also be accomplished by attaching ground wire(s) to ground lug(s) provided in the unit wiring compartment.
- Ground lug(s) are located close to wire entrance on left side of unit(up-flow). Lug(s) may be moved to marked locations near wire entrance on right side of unit(up-flow). If alternate location is more convenient.
- Use of multiple supply circuits require grounding of each circuit to lug(s) provided in unit.

3.4 Electrical Data

Series	Model	Voltage	Hz	HP	Speed	Circuit Amps.	Maximum circuit protector
Regular Air Handler	18K	208/230V	60	1/4	3	1.8	3(A)
	24K			2/7	3	2.3	3(A)
	30K			1/2	5	2.8	3(A)
	36K			1/2	5	4.0	6(A)
	42K			3/4	5	4.5	6(A)
	48K			3/4	5	5.2	6(A)
	60K			3/4	5	5.4	6(A)
Front Return Air Handler	18K	208/230V	60	1/3	5	2.2	3(A)
	24K			1/3	5	2.9	3(A)
	30K			1/2	5	3.5	6(A)
	36K			1/2	5	3.8	6(A)

4. Airflow Performance

Airflow performance data is based on cooling performance with a dry coil and no filter in place. Select performance table for appropriate unit size external static pressure applied to unit allows operation within the minimum and maximum limits shown in table below for both cooling and electric heater operation.

Regular Air Handler:

Model	Blower Speeds	External Static Pressure (in.w.c.)								
		0	0.1	0.2	0.3	0.4	0.5	0.6	0.7	0.8
18K	L-Factory Default	934	882	813	719	651	579	534	/	/
	M	1143	1096	1045	981	866	788	708	618	557
	H	1194	1147	1094	1034	915	825	741	646	556
24K	L-Factory Default	1186	1139	1082	1024	901	801	715	604	554
	M	1256	1204	1149	1085	944	845	755	655	559
	H	1360	1305	1247	1179	1092	932	828	729	582
30K	1	1153	/	1041	/	881	819	787	/	674
	2	1278	1235	1176	1111	1015	960	898	854	811
	3-Factory Default	1378	1338	1298	1243	1164	1085	1036	974	929
	4	1479	/	1400	/	1290	1203	1156	/	997
	5	1575	/	1492	/	1401	1331	1239	/	1025
36K	1	1153	/	1041	/	881	819	787	/	674
	2	1278	1235	1176	1111	1015	960	898	854	811
	3	1378	1338	1298	1243	1164	1085	1036	974	929
	4-Factory Default	1479	/	1400	/	1290	1203	1156	/	997
	5	1575	/	1492	/	1401	1331	1239	/	1025
42K	1	1202	/	1118	/	952	891	859	/	741
	2	1366	/	1280	/	1165	1064	1012	/	919
	3-Factory Default	1527	1488	1452	1415	1369	1320	1281	1142	1058
	4	1672	/	1592	/	1516	1476	1440	/	1089
	5	1821	/	1747	/	1644	1562	1484	/	1092
48K	1	1295	/	1200	/	1076	971	915	/	803
	2	1478	/	1385	/	1283	1232	1196	/	1015
	3	1668	/	1582	/	1506	1461	1415	/	1296
	4-Factory Default	1821	1778	1742	1706	1671	1630	1594	1534	1490
	5	1986	/	1911	/	1837	1797	1769	/	1597
60K	1	1295	/	1200	/	1076	971	915	/	803
	2	1478	/	1385	/	1283	1232	1196	/	1015
	3	1668	/	1582	/	1506	1461	1415	/	1296
	4-Factory Default	1821	1778	1742	1706	1671	1630	1594	1534	1490
	5	1986	/	1911	/	1837	1797	1769	/	1597

Front Return Air Handler:

Model	Blower Speeds	External Static Pressure (in. w.c.)								
		0	0.1	0.2	0.3	0.4	0.5	0.6	0.7	0.8
18K	1	812	783	741	698	669	619	586	525	474
	2-Factory Default	916	875	851	812	786	746	717	673	634
	3	1005	978	941	917	882	856	819	792	752
	4	1122	1096	1061	1036	1002	971	942	917	880
	5	1239	1214	1182	1158	1127	1088	1051	992	919
24K	1	812	783	741	698	669	619	586	525	474
	2	916	875	851	812	786	746	717	673	634
	3-Factory Default	1005	978	941	917	882	856	819	792	752
	4	1122	1096	1061	1036	1002	971	942	917	880
	5	1239	1214	1182	1158	1127	1088	1051	992	919
30K	1	935	866	811	770	704	636	547	492	424
	2	1059	1009	960	921	871	829	751	692	616
	3	1150	1116	1069	1036	988	953	912	850	779
	4-Factory Default	1282	1235	1203	1158	1131	1076	1050	1015	953
	5	1404	1374	1335	1306	1265	1231	1195	1150	1115
36K	1	935	866	811	770	704	636	547	492	424
	2	1059	1009	960	921	871	829	751	692	616
	3	1150	1116	1069	1036	988	953	912	850	779
	4	1282	1235	1203	1158	1131	1076	1050	1015	953
	5-Factory Default	1404	1374	1335	1306	1265	1231	1195	1150	1115

--- Shaded boxes represent airflow outside the required 300-450 cfm/ton.

NOTES: Airflow based upon cooling performance at 230V with no electric heater and no filter. Airflow at 208V is approximately the same as 230V because the multi-tap ECM motor is a constant torque motor. The torque doesn't drop off at the speeds in which the motor operates.

The air distribution system has the greatest effect on airflow. The duct system is totally controlled by the contractor. For this reason, the contractor should use only industry-recognized procedures.

Heat pump systems require a specified airflow. Each ton of cooling requires between 350 and 450 cubic feet of air per minute (CFM), or 400 CFM nominally.

Duct design and construction should be carefully done. System performance can be lowered dramatically through bad planning or workmanship.

Air supply diffusers must be selected and located carefully. They must be sized and positioned to deliver treated air along the perimeter of the space. If they are too small for their intended airflow, they become noisy. If they are not located properly, they cause drafts. Return air grilles must be properly sized to carry air back to the blower. If they are too small, they also cause noise. The installers should balance the air distribution system to ensure proper quiet airflow to all rooms in the home. This ensures a comfortable living space.

An air velocity meter or airflow hood can be used to balance and verify branch and system airflow (CFM).

5. Ductwork

Field ductwork must comply with the National Fire Protection Association NFPA 90A, NFPA 90B and any applicable local ordinance.

WARNING



Do not, under any circumstances, connect return ductwork to any other heat producing device such as fireplace insert, stove, etc. Unauthorized use of such devices may result in fire, carbon monoxide poisoning, explosion, personal injury or property damage.

Sheet metal ductwork run in unconditioned spaces must be insulated and covered with a vapor barrier. Fibrous ductwork may be used if constructed and installed in accordance with SMACNA Construction Standard on Fibrous Glass Ducts.

Ductwork must comply with National Fire Protection Association as tested by U/L Standard 181 for Class I Air Ducts. Check local codes for requirements on ductwork and insulation.

- Duct system must be designed within the range of external static pressure the unit is designed to operate against. It is important that the system airflow be adequate. Make sure supply and return ductwork, grilles, special filters, accessories, etc. are accounted for in total resistance. See airflow performance tables in this manual.
- Design the duct system in accordance with "ACCA" Manual "D" Design for Residential Winter and Summer Air Conditioning and Equipment Selection. Latest editions are available from: "ACCA" Air Conditioning Contractors of America, 1513 16th Street, N.W., Washington, D.C. 20036. If duct system incorporates flexible air duct, be sure pressure drop information (straight length plus all turns) shown in "ACCA" Manual "D" is accounted for in system.
- Supply plenum is attached to the 3/4" duct flanges supplied with the unit. Attach flanges around the blower outlet.

IMPORTANT: If an elbow is included in the plenum close to the unit, it must not be smaller than the dimensions of the supply duct flange on the unit.

- **IMPORTANT:** The front flange on the return duct if connected to the blower casing must not be screwed into the area where the power wiring is located. Drills or sharp screw points can damage insulation on wires located inside unit.
- Secure the supply and return ductwork to the unit flanges, using proper fasteners for the type of duct used and tape the duct-to-unit joint as required to prevent air leaks.

6. Refrigerant Connections

Keep the coil connections sealed until refrigerant connections are made. See the Installation Instructions for the outdoor unit for details on line sizing, tubing installation, and charging information.

Coil is shipped with “No charge”. Evacuate the system before charging with refrigerant.

Install refrigerant tubing so that it does not block service access to the front of the unit.

Nitrogen should flow through the refrigerant lines while brazing.

Use a brazing shield to protect the cabinet’s paint and a wet rag to protect the rubber grommet from being damaged by torch flames.

After the refrigerant connections are made, seal the gap around the connections with pressure sensitive gasket.

6.1 Condensate Drain Tubing

Consult local codes for specific requirements.

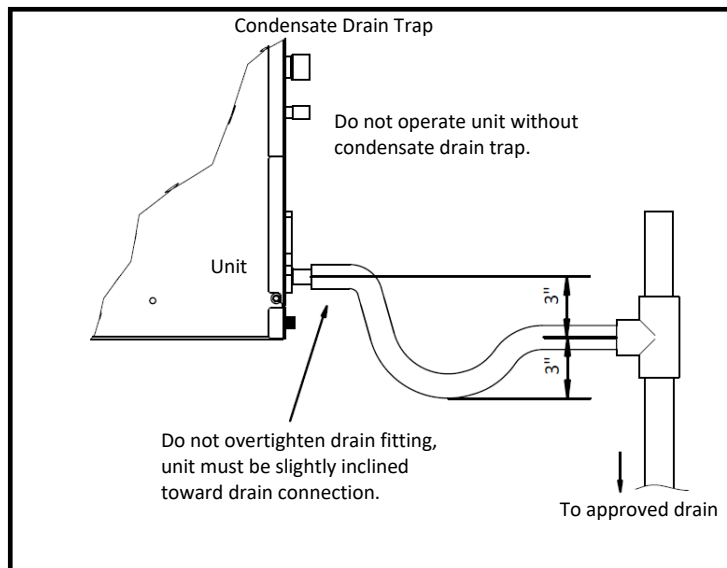

IMPORTANT:

1. When making drain fitting connections to the drain pan, use a thin layer of Teflon paste, silicone or Teflon tape and install, hand tighten.
 2. When making drain fitting connections to drain pan, do not overtighten. Over tightening fittings can split pipe connections on the drain pan.
- Install drain lines so they do not block service access to front of the unit. Minimum clearance of 24 inches is required for filter, coil or blower removal and service access.
 - Make sure unit is level or pitched slightly toward primary drain connection so that water will drain completely from the pan.
 - Do not reduce drain line size less than connection size provided on condensate drain pan.
 - All drain lines must be pitched downward away from the unit a minimum of 1/8" per foot of line to ensure proper drainage.
 - Do not connect condensate drain line to a closed or open sewer pipe. Run condensate to an open drain or run line to a safe outdoor area.
 - The drain line should be insulated where necessary to prevent sweating and damage due to condensate forming on the outside surface of the line.
 - Make provisions for disconnecting and cleaning of the primary drain line should it become necessary. Install a 3-inch trap in the primary drain line as close to the unit as possible. Make sure that the top of the trap is below connection to the drain pan to allow complete drainage of pan.
 - Auxiliary drain line should be run to a place where it will be noticeable if it becomes operational. Homeowner should be warned that a problem exists if water should begin running from the auxiliary drain line.
 - Plug the unused drain connection with the plugs provided in the accessory bag, using a thin layer of teflon paste, silicone or teflon tape to form a water tight seal.
 - Test condensate drain pan and drain line after installation is complete. Pour water into drain pan, enough to fill drain trap

and line. Check to make sure drain pan is draining completely, no leaks are found in drain line fittings, and water is draining from the termination of the primary drain line.

Front Return Air Handler

The unit is supplied with primary and auxiliary condensate drains that have 3/4" NPT connections. Both drains must be trapped outside the unit and piped in accordance with applicable materials and building codes. Do not reduce the drain line size less than the connection size on the drain pan. Condensate should be piped to an open drain or to the outside. All drains must pitch downward away from the unit a minimum of 1/4" per foot of line to ensure proper drainage. Insulate the primary drain line to prevent sweating where dew point temperatures may be met. (Insulation is optional depending on climate and application needs.)

Important: If cleanout Tee is used, standpipe must be sealed/capped.

7. Air Filter (not factory-installed)

External filter or other means of filtration is required. Units should be sized for a maximum of 300 feet/min. Air velocity or what is recommended for the type filter installed.

Filter application and placement are critical to airflow, which may affect the heating and cooling system performance. Reduced airflow can shorten the life of the system's major components, such as motor, limits, elements, heat relays, evaporator coil or compressor. Consequently, we recommend that the return air duct system have only one filter location. For systems with a return air filter grille or multiple filter grilles, can have a filter installed at each of the return air openings.

If adding high efficiency filters or electronic air filtration systems, it is very important that the air flow is not reduced. If air flow is reduced the overall performance and efficiency of the unit will be reduced. It is strongly recommended that a professional installation technician is contacted to ensure installation of these such filtration systems are installed correctly.

IMPORTANT: DO NOT DOUBLE FILTER THE RETURN AIR DUCT SYSTEM. DO NOT FILTER THE SUPPLY AIR DUCT SYSTEM. THIS WILL CHANGE THE PERFORMANCE OF THE UNIT AND REDUCE AIRFLOW.

WARNING



Do not operate the system without filters. A portion of the dust entrained in the air may temporarily lodge in the duct runs and at the supply registers. Any circulated dust particles could be heated and charred by contact with the air handler elements. This residue could soil ceilings, walls, drapes, carpets and other articles in the house. Soot damage may occur with filters in place, when certain types of candles, oil lamps or standing pilots are burned.

8. Filter Installation Dimensions

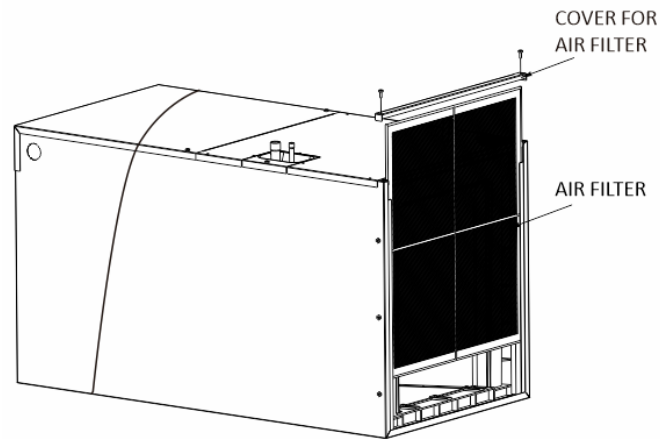

Dimension data

SERIES	MODEL	FILTER SIZE IN [mm]
Regular Air Handler	18/24/30/36/42	18.1×21.4 [460×544]
	48/60	20.5×23.8 [521×605]
Front Return Air Handler	18/24	15×19 [381×483]
	30/36	20×20 [508×508]

NOTE: The thickness of the filter should be within 1"[25mm].

AIR FILTER REMOVAL / INSTALLATION

1. Remove bolts manually, remove air filter recover;
2. Hold the edge of the air filter and extract out;
3. Clean the air filter (Vacuum cleaner or pure water may be used to clean the air filter. If the dust accumulation is too heavy, use soft brush and mild detergent to clean it and dry out in cool place).

9. Wiring Diagram

1. To avoid the electrical shock, please connect the air conditioner with the ground lug. The main power plug in the air conditioner has been joined with the ground wiring, please don't change it freely.
2. The power socket is used as the air conditioner specially.
3. Don't pull the power wiring hard.
4. When connecting the air conditioner with the ground, observe the local codes.
5. If necessary, use the power fuse or the circuit, breaker or the corresponding scale ampere.

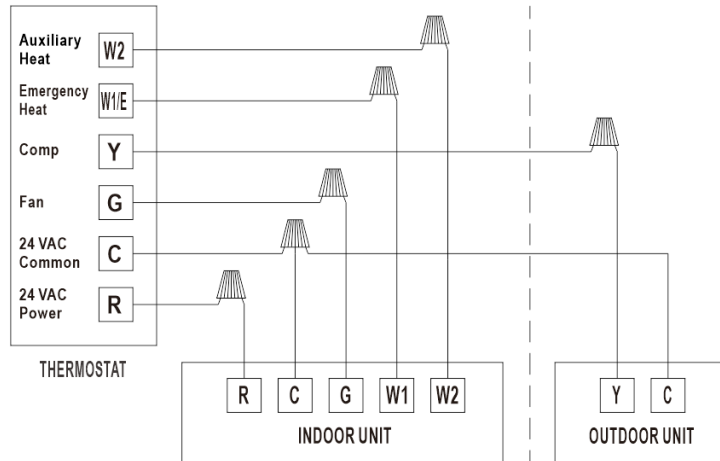

Wiring connection for A/C Systems

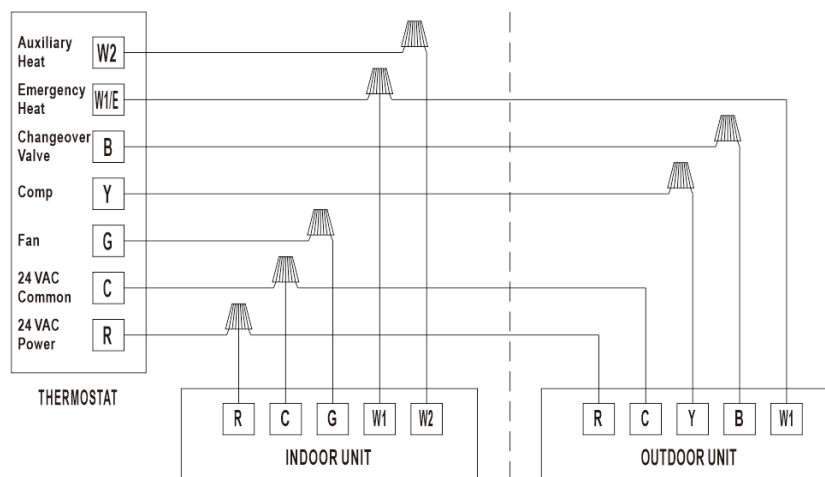

Wiring connection for H/P Systems

WARNING



High Voltage: Disconnect all power before servicing or installing this unit. Multiple power sources may be present. Failure to do so may cause property damage, personal injury, or death.

10. Electrical Wiring Gauge

NOTE: The cross-section areas of wires or lines should not be less than the corresponding ones listed in the table below; besides, if the power wires is quite long from the unit, please choose the windings with larger cross-section area to guarantee the normal power supply.

Model (AC)			18K	24K	30K	36K	42K	48K	60K
Line gauge	Indoor unit power line	Line quantity	3	3	3	3	3	3	3
		Line diameter (AWG)	16	16	16	16	16	16	16
	Outdoor unit power line	Line quantity	3	3	3	3	3	3	3
		Line diameter (AWG)	14	14	12	12	10	10	8
	Indoor-thermostat signal line	Line quantity	5	5	5	5	5	5	5
		Line diameter (AWG)	18	18	18	18	18	18	18
	Outdoor-thermostat signal line	Line quantity	2	2	2	2	2	2	2
		Line diameter (AWG)	18	18	18	18	18	18	18

Model (HP)			18K	24K	30K	36K	42K	48K	60K
Line gauge	Indoor unit power line	Line quantity	3	3	3	3	3	3	3
		Line diameter (AWG)	16	16	16	16	16	16	16
	Outdoor unit power line	Line quantity	3	3	3	3	3	3	3
		Line diameter (AWG)	14	14	12	12	10	10	8
	Indoor-thermostat signal line	Line quantity	5	5	5	5	5	5	5
		Line diameter (AWG)	18	18	18	18	18	18	18
	Outdoor-thermostat signal line	Line quantity	5	5	5	5	5	5	5
		Line diameter (AWG)	18	18	18	18	18	18	18

Part 5

Troubleshooting

1. Control logic description.....	57
2. Sensor.....	57
3. Exploded views	57
4. Main PCB Ports	61
5. Fault code table.....	64
6. Troubleshooting.....	65

1. Control logic description

The fixed speed system adopts the same control communication command as that of common heat pump and air conditioning unit, it is the 24V control command.

2. Sensor

- T3 (Outdoor coil temperature)
- T4 (ambient temperature)
- T5 (compressor discharge temperature)

3. Exploded views

Cooling only outdoor unit:

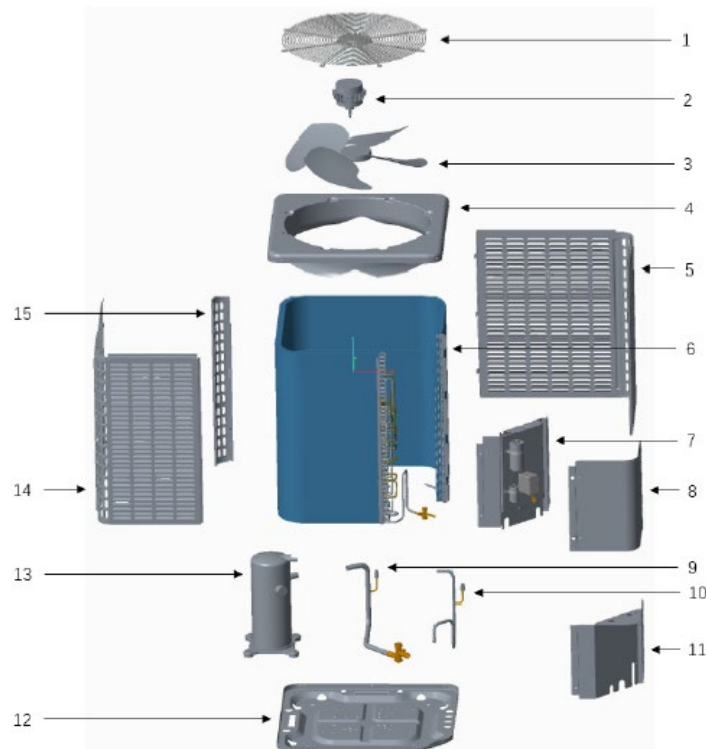

No.	Part Name	Quantity	No.	Part Name	Quantity
1	Top air outlet grille	1	7.3	AC contactor	1
2	Fan motor	1	7.4	Compressor capacitor	1
3	Axial-flow fan	1	7.5	Fan capacitor	1
4	Top cover	1	7.6	Brass binding post	1
5	Right side panel	1	8	Upper side panel	1
6	Condenser assembly	1	9	Gas return pipe assembly	1
6.1	Condenser component	1	10	Exhaust pipe assembly	1
6.2	Shunt components	1	11	Lower side panel	1
6.3	Gas collector assembly	1	12	Base pan components	1
6.4	High pressure valve assembly	1	13	Compressor	1
7	Electronic control part	1	14	Left side panel	1
7.1	Electronic control mounting plate	1	15	Support plate	1
7.2	PCB mounting base	1			

Heat pump outdoor unit:

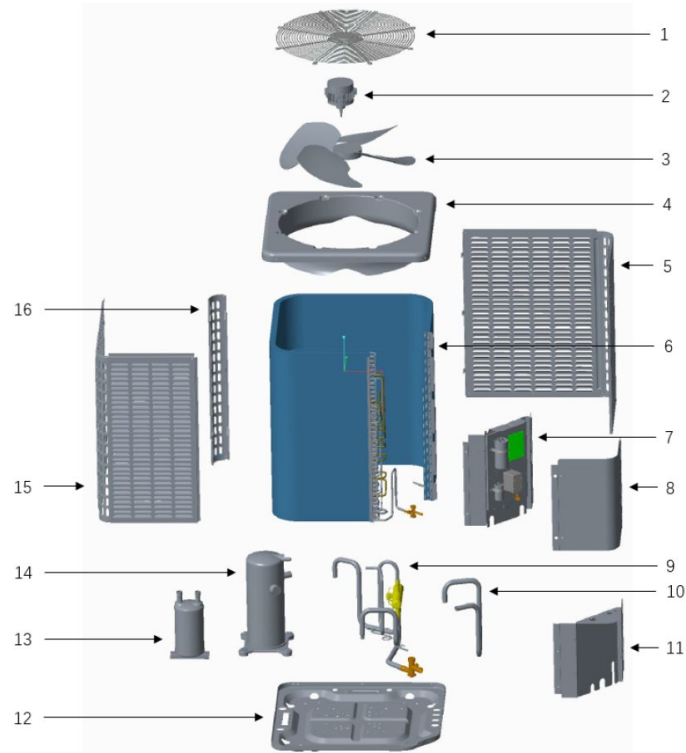

No.	Part Name	Quantity	No.	Part Name	Quantity
1	Top air outlet grille	1	7.6	Fan capacitor	1
2	Fan motor	1	7.7	Brass binding post	1
3	Axial-flow fan	1	7.8	Ambient temperature sensor	1
4	Top cover	1	8	Upper side panel	1
5	Right side panel	1	9	4-way valve assembly	1
6	Condenser assembly	1	10	Gas return pipe assembly	1
6.1	Condenser component	1	11	Lower side panel	1
6.2	Shunt components	1	12	Base pan components	1
6.3	Gas collector assembly	1	13	Compressor	1
6.4	High pressure valve assembly	1	14	Gas-liquid separator	1
7	Electronic control part	1	15	Left side panel	1
7.1	Electronic control mounting plate	1	16	Support plate	1
7.2	PCB mounting base	1	17	Crankshaft heating belt	1
7.3	PCB	1	18	Condenser temperature sensor	1
7.4	AC contactor	1	19	Discharge temperature sensor	1
7.5	Compressor capacitor	1	20	4-way valve coil	1

Regular Air Handler:

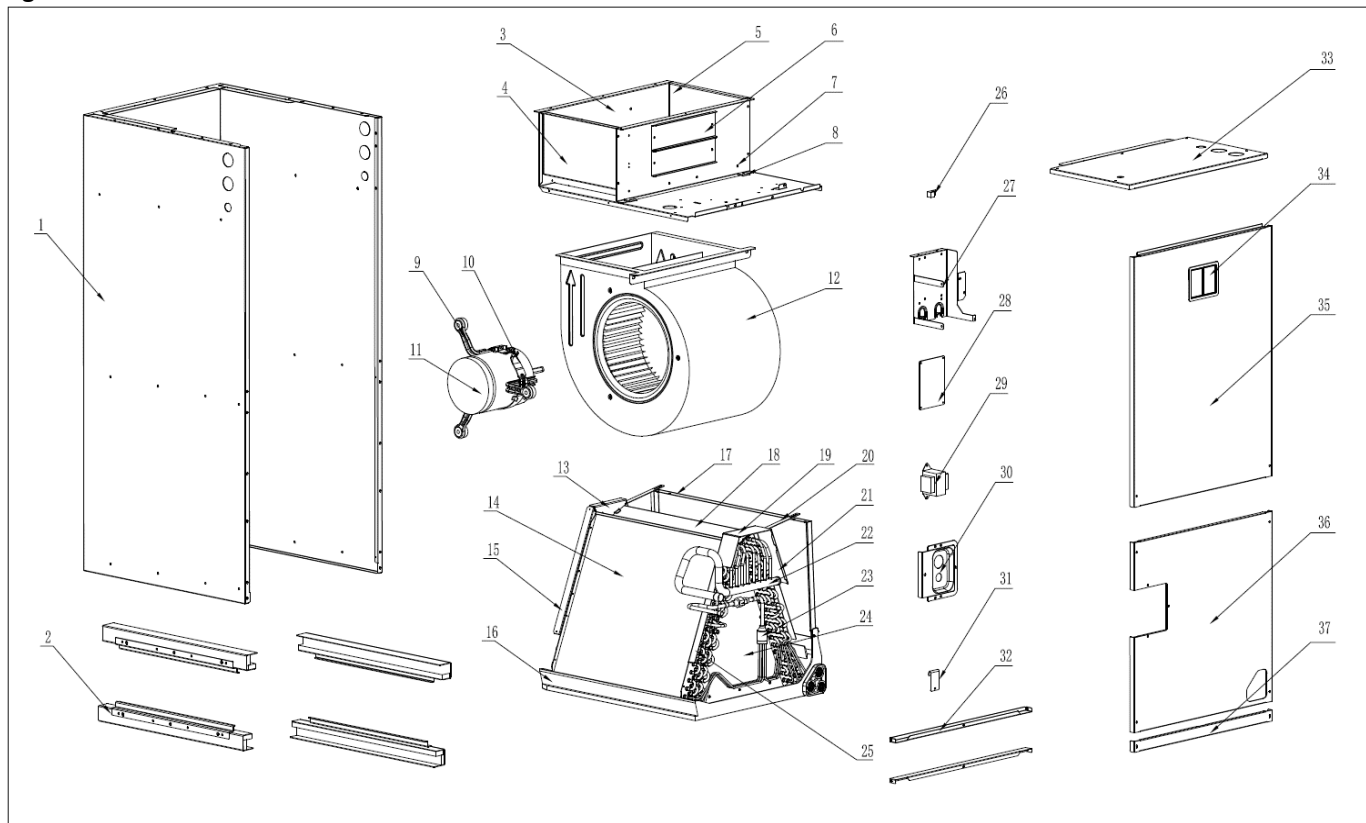

No.	Part Name	Quantity	No.	Part Name	Quantity
1	Base pan cotton sticking assembly	1	20	Connecting plate	2
2	Drain pan support plate cotton sticking assembly	4	21	Evaporator water baffle 3	1
3	Wind wheel fixing plate	1	22	Evaporator gas collector pipe assembly	1
4	Left side panel of air duct	1	23	Evaporator shunt pipe assembly	1
5	Right side panel of air duct	1	24	Evaporator connecting plate	2
6	Electric heater sealing plate	2	25	Evaporator water baffle 2	1
7	Front side panel of air duct	1	26	Brass binding post	1
8	Wind wheel mounting block	2	27	Electric control mounting plate	1
9	Motor fixing beam assembly	3	28	PCB	1
10	Motor clamp	1	29	Transformer	1
11	Fan motor	1	30	Piping cover cotton sticking assembly	1
12	Wind wheel volute	1	31	Drain pan fixing block	1
13	Evaporator fixing plate 1	1	32	Support bar	2
14	Evaporator	2	33	Electric control box cover cotton sticking assembly	1
15	Evaporator water baffle 1	2	34	Circuit breaker sealing plate	1
16	Plastic drain pan cotton sticking assembly	1	35	Upper side panel cotton sticking assembly	1
17	Sheet metal drain pan cotton sticking assembly	1	36	Lower side panel cotton sticking assembly	1
18	Evaporator sealing plate cotton sticking assembly	1	37	Filter cover	1
19	Evaporator fixing plate 2	1			

Front Return Air Handler:

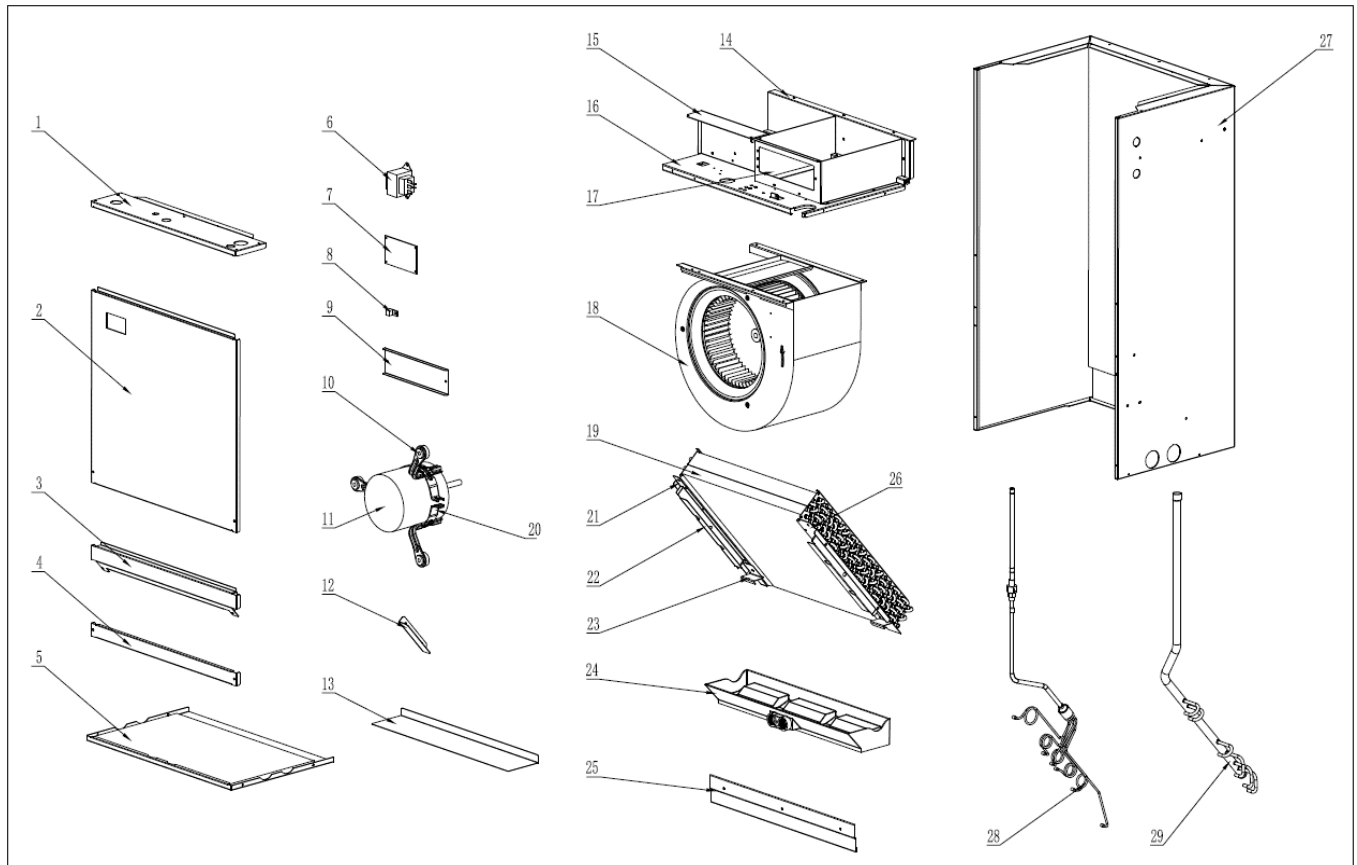

No.	Part Name	Quantity	No.	Part Name	Quantity
1	Electric control cover cotton sticking assembly	1	16	Volute fixing plate cotton sticking assembly	1
2	Upper side panel cotton sticking assembly	1	17	Air duct panel	1
3	Sealing plate cotton sticking assembly	1	18	Wind wheel volute	1
4	Lower reinforcement plate	1	19	Evaporator	1
5	Lower side panel cotton sticking assembly	1	20	Motor clamp	1
6	Transformer	1	21	Evaporator left connecting plate	1
7	PCB	1	22	Filter rail	2
8	Brass binding post	1	23	Drain pan fixing block	2
9	Electric heater sealing plate	1	24	Plastic drain pan cotton sticking assembly	1
10	Motor fixing beam assembly	3	25	Rear mounting plate	2
11	Fan motor	1	26	Evaporator right connecting plate	1
12	Limit plate	1	27	Base pan cotton sticking assembly	1
13	Drain pan support plate	1	28	Evaporator shunt pipe assembly	1
14	Rear side panel of air duct	1	29	Evaporator gas collector pipe assembly	1
15	Electric control mounting plate	1			

4. Main PCB Ports

For 18K-48K heat pump models:

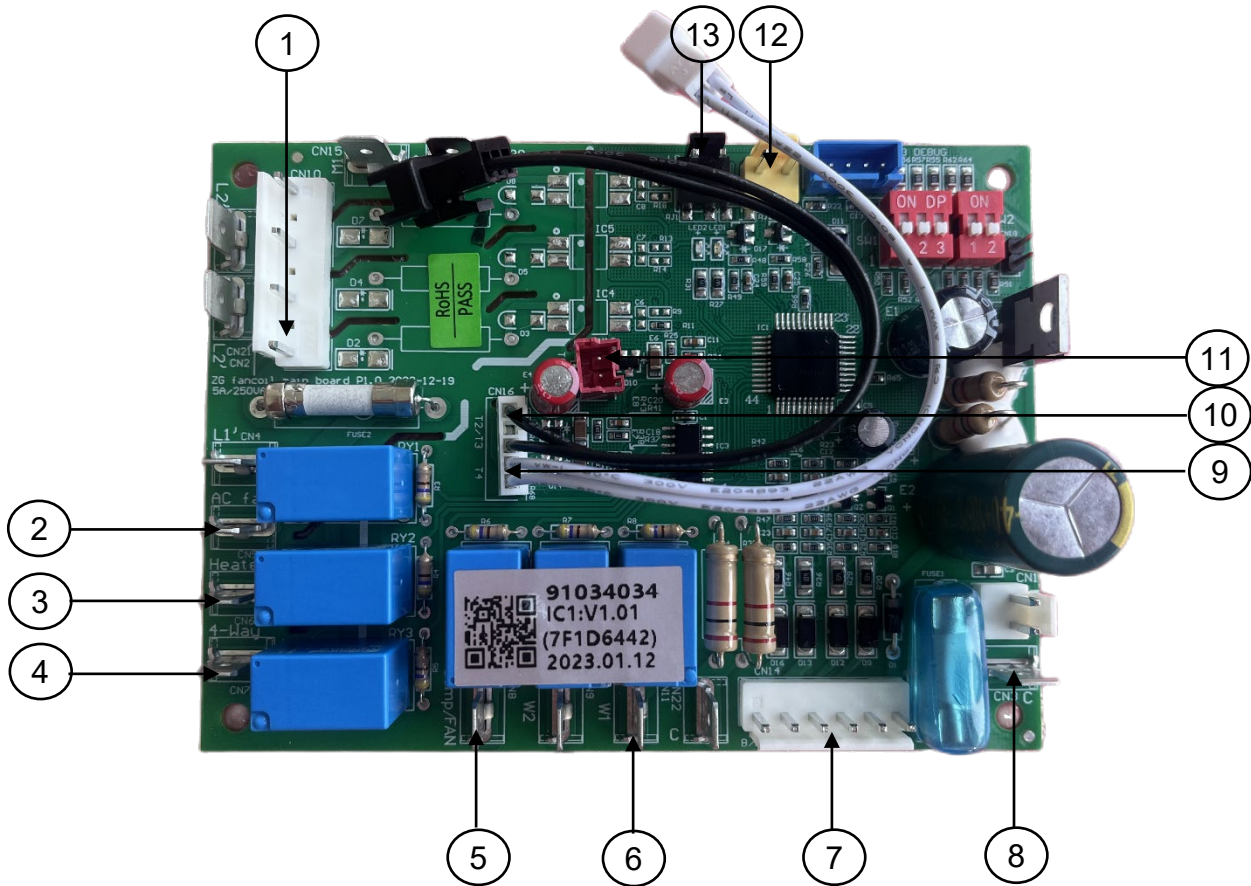

No.	Content	No.	Content
1	Power (L1)	8	24VAC common
2	AC fan motor	9	T4 temperature sensor
3	Crankshaft heating belt	10	T3 temperature sensor
4	4-way valve coil	11	T5 temperature sensor
5	Compressor	12	High pressure switch
6	Defrost signal	13	Low pressure switch
7	24V control port		

For 60K heat pump model:

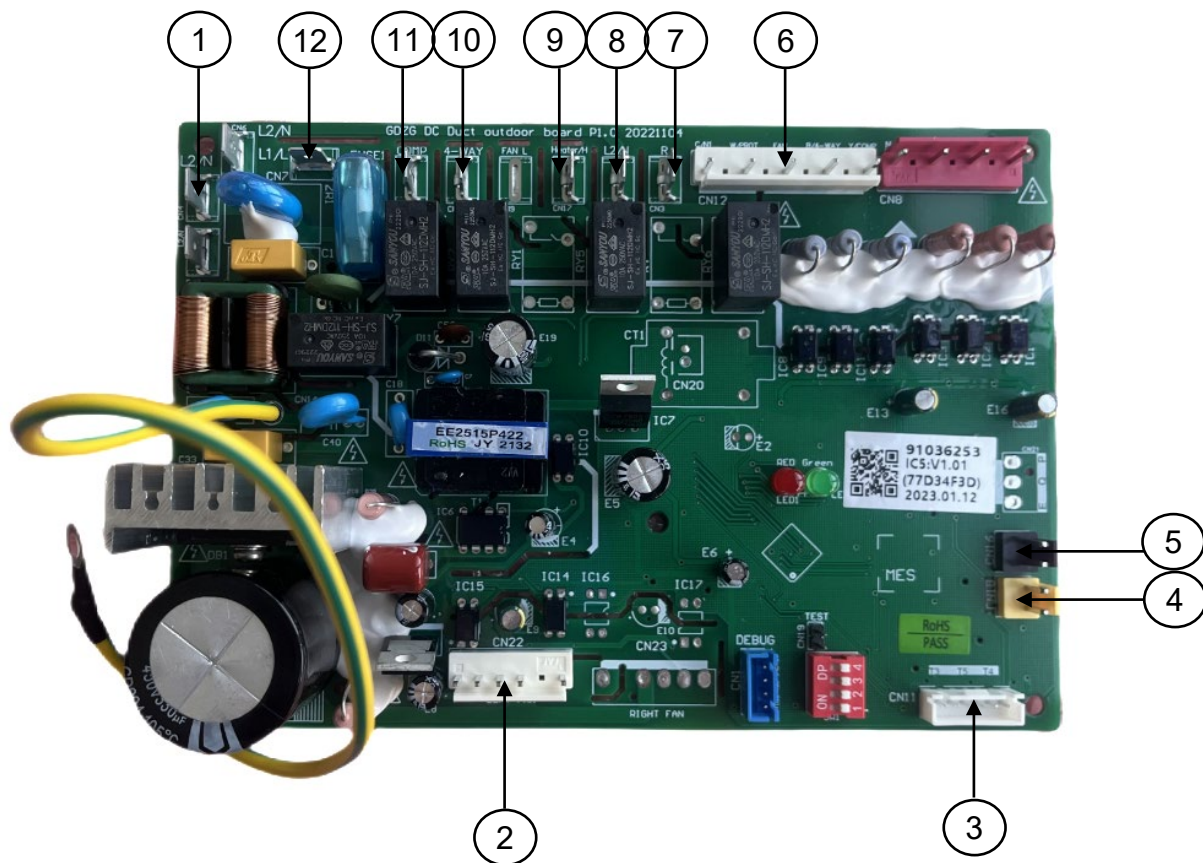

No.	Content	No.	Content
1	Power (L2)	7	24VAC power
2	DC fan motor	8	Power (L2)
3	Temperature sensor group	9	Crankshaft heating belt
4	High pressure switch	10	4-way valve coil
5	Low pressure switch	11	Compressor
6	24V control port	12	Power (L1)

For indoor units:

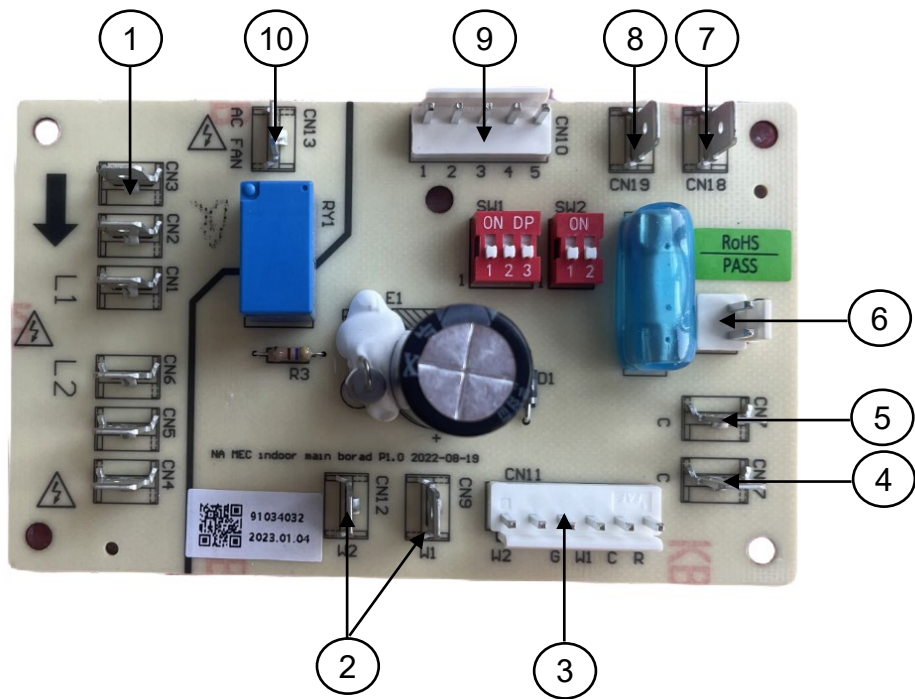

No.	Content	No.	Content
1	Power	6	24VAC power
2	E-heater	7	Reserved
3	24V control port	8	Reserved
4	24VAC common	9	ECM fan motor
5	24VAC common	10	AC fan motor

5. Fault code table

	Display	Description
No Fault: Green light flashes Red light off	Green light flashes slowly	Normal standby
	Green light normally on	Normal running
System fault: Green light flashes Red light on	(T3) Temperature sensor fault	Green light flashes twice every 8 seconds
	(T4) Temperature sensor fault	Green light flashes 9 times every 8 seconds
	(T5) Temperature sensor fault	Green light flashes 8 times every 8 seconds
	Low pressure fault	Green light flashes 6 times every 8 seconds
	High pressure fault	Green light flashes once every 8 seconds
	(T3) High temperature protection	Green light flashes 10 times every 8 seconds
	(T5) High exhaust temperature protection	Green light flashes 5 times every 8 seconds
	DC fan not connected fault	Green light flashes 7 times every 8 seconds

6. Troubleshooting

(T3) Temperature sensor fault:

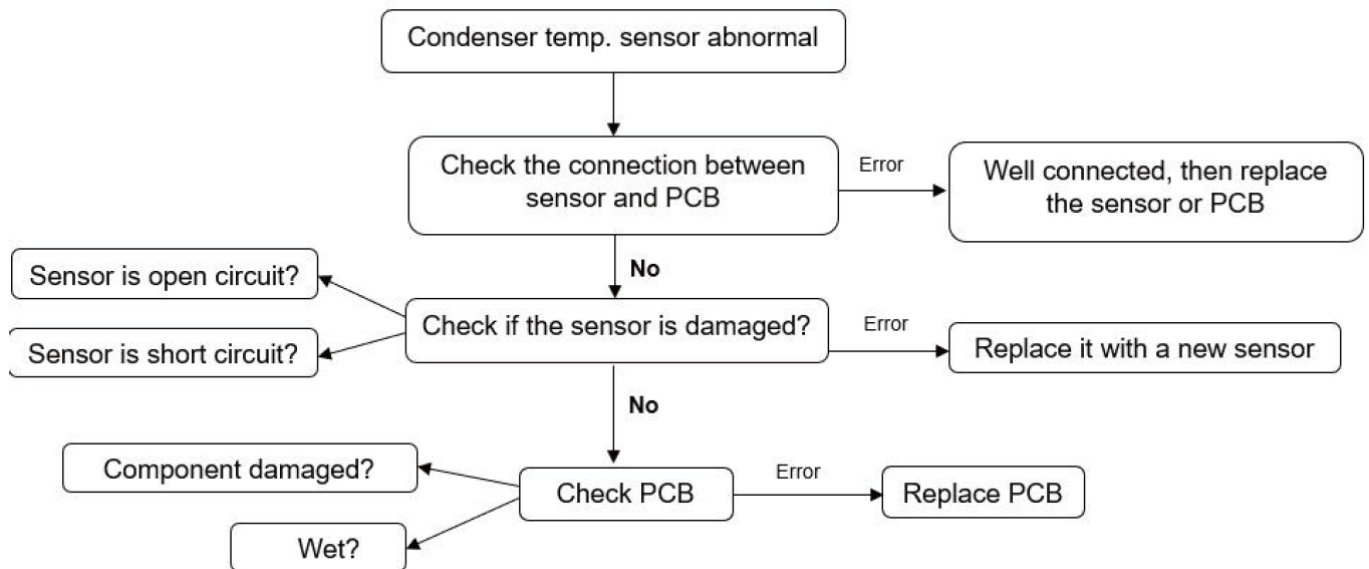

(T4) Temperature sensor fault:

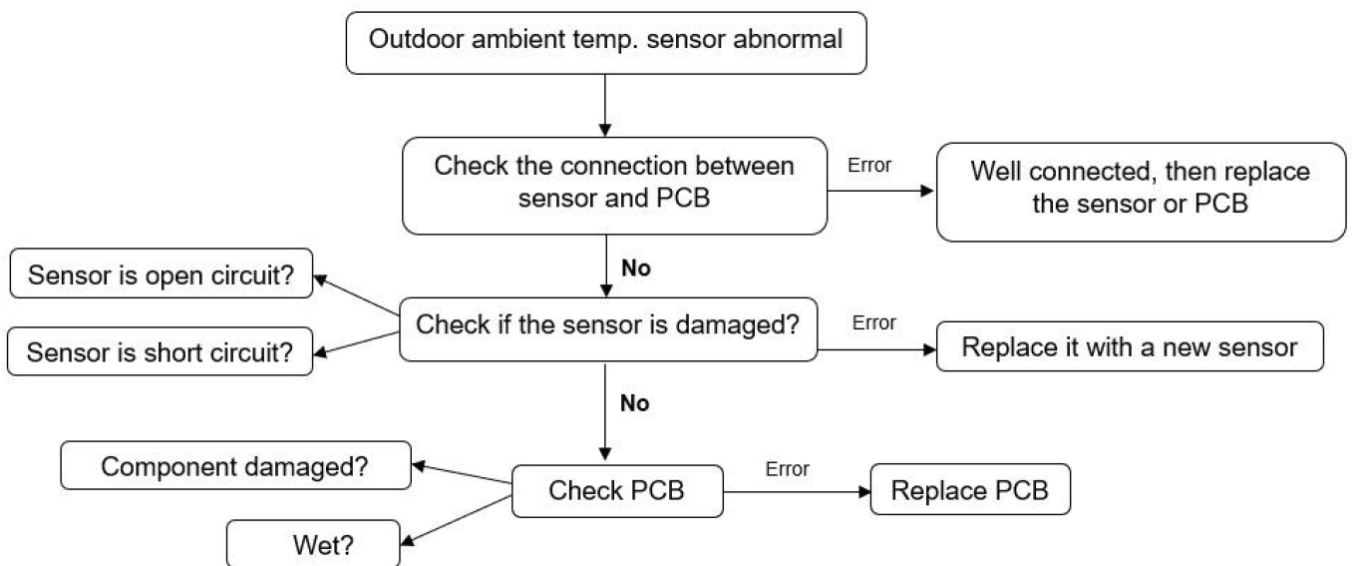

(T5) Temperature sensor fault:

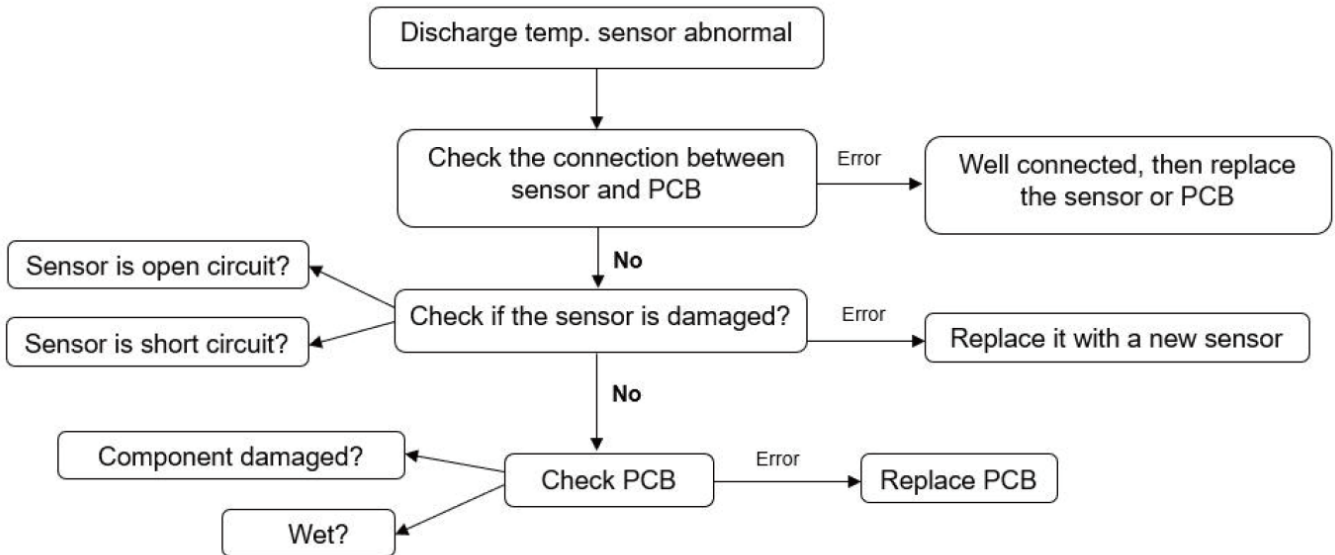

Low pressure fault:

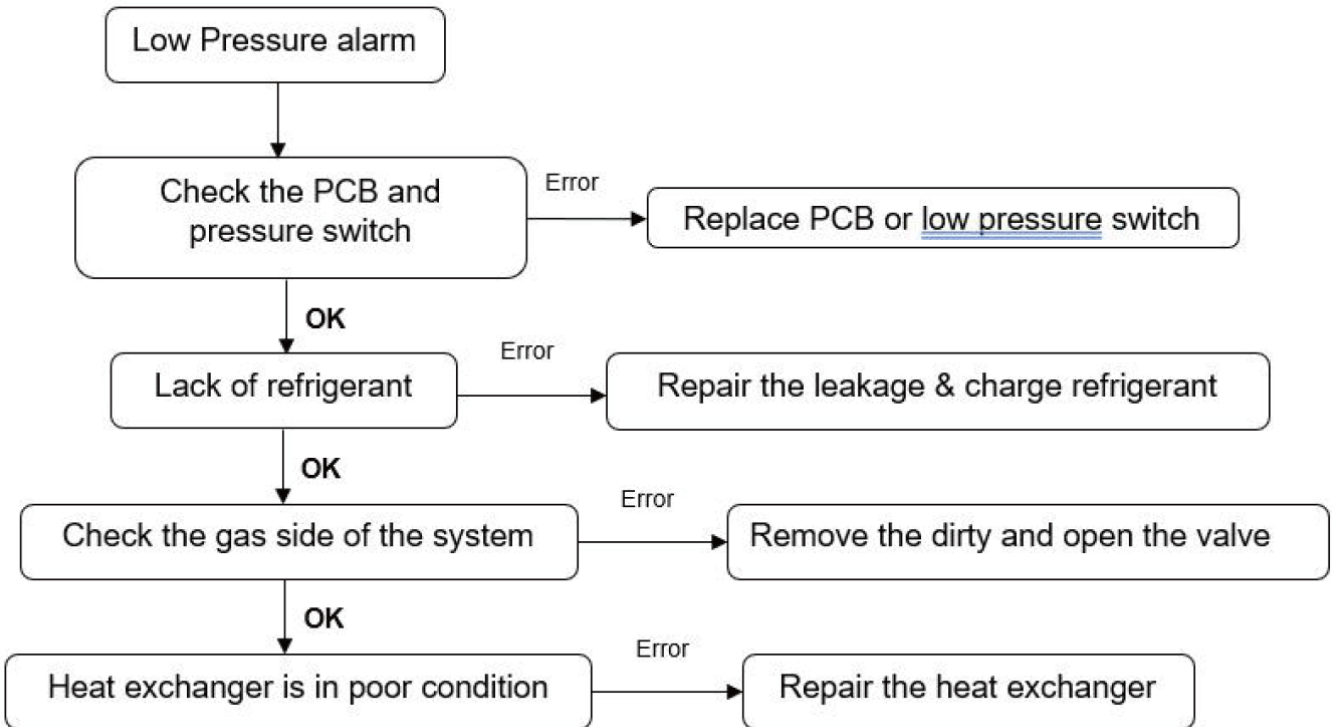

High pressure fault:

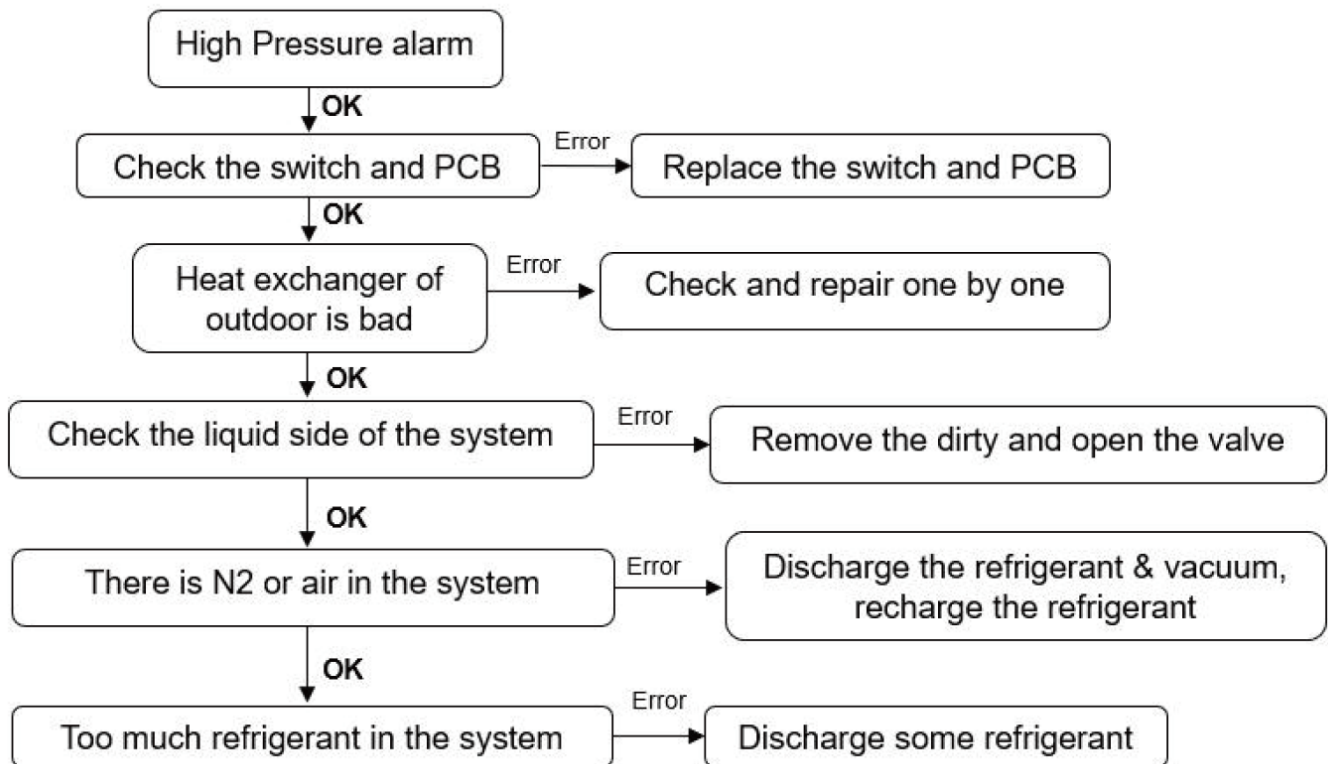

(T3) High temperature protection:

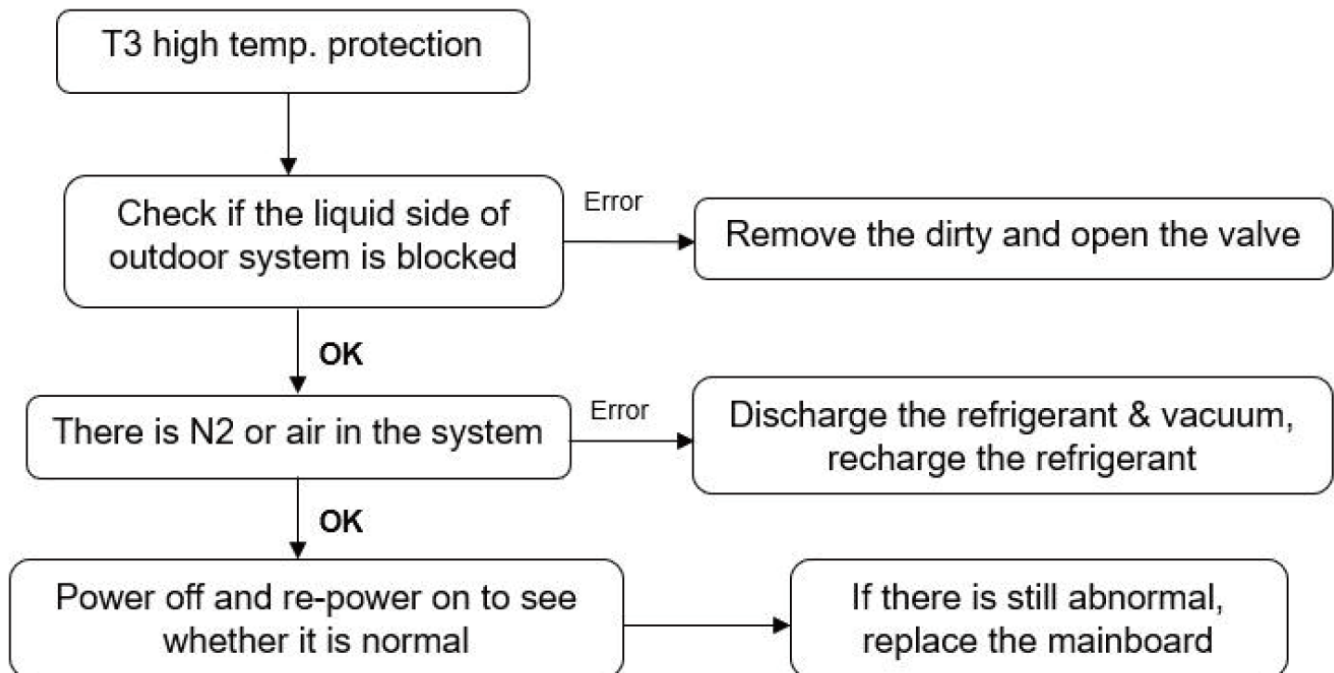

(T5) High exhaust temperature protection:

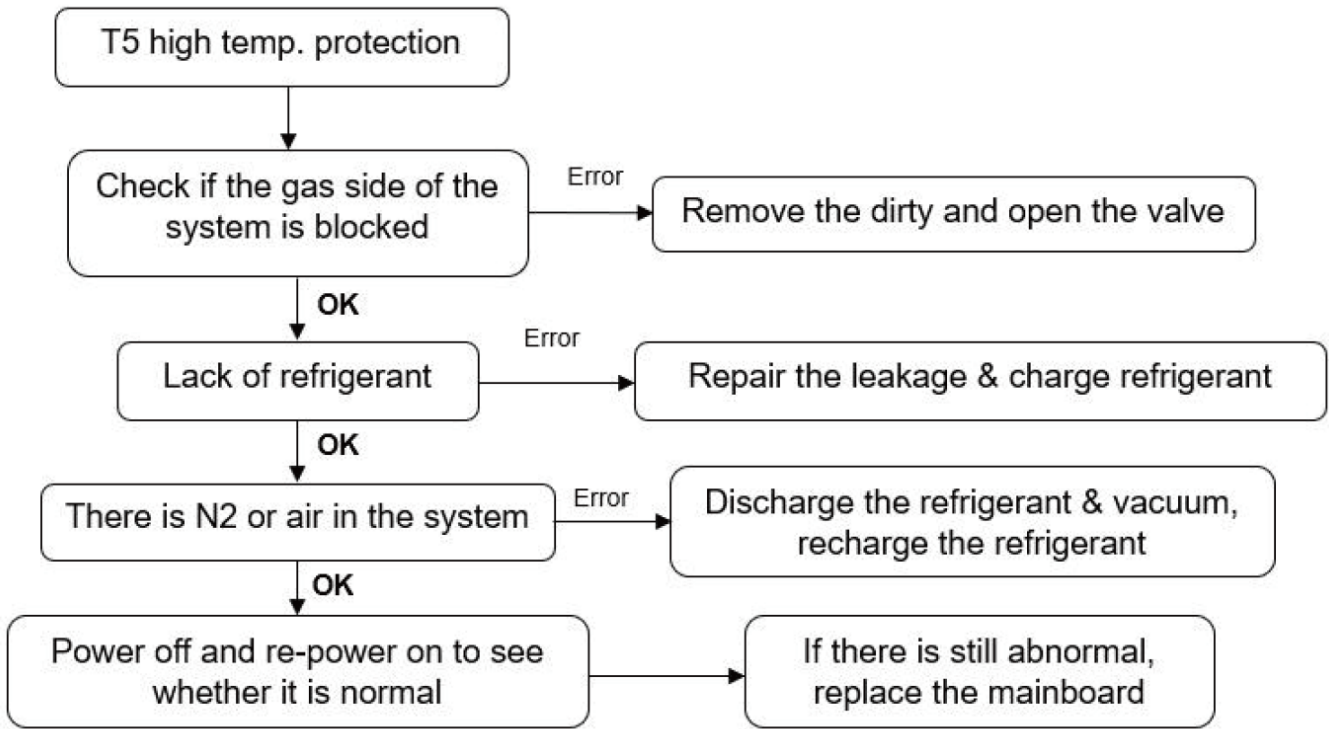

DC fan not connected fault:

