



Submittal Sheet for Saturn Series

Cooling Only Outdoor Unit	Heat Pump Outdoor Unit	Air Handler	Front Return Air Handler
ATSCV4C4T18	ATSCV4H4T18	ATSEM4H4T18	ATSEFR4H4T18
ATSCV4C4T24	ATSCV4H4T24	ATSEM4H4T24	ATSEFR4H4T24
ATSCV4C4T30	ATSCV4H4T30	ATSEM4H4T30	ATSEFR4H4T30
ATSCV4C4T36	ATSCV4H4T36	ATSEM4H4T36	ATSEFR4H4T36
ATSCV4C4T42	ATSCV4H4T42	ATSEM4H4T42	
ATSCV4C4T48	ATSCV4H4T48	ATSEM4H4T48	
ATSCV4C4T60	ATSCV4H4T60	ATSEM4H4T60	

Job Name: \_\_\_\_\_

Date: \_\_\_\_\_

Contractor: \_\_\_\_\_

Location: \_\_\_\_\_

Engineer: \_\_\_\_\_

Tag: \_\_\_\_\_

Submitted for:

Approval

Record

Model		ATSCV4C4T18	ATSCV4C4T24	ATSCV4C4T30	ATSCV4C4T36	ATSCV4C4T42	ATSCV4C4T48	ATSCV4C4T60
<b>Voltage, Frequency, Phase</b>		230V, 60Hz, 1P						
<b>Cooling Capacity</b>	Btu/h	17500	23400	28000	33000	40000	45000	55500
	W	5129	6858	8206	9671	11723	13188	16265
<b>EER</b>	Btu/Wh	11.70	11.70	11.70	11.70	11.70	11.20	11.20
<b>SEER</b>	Btu/Wh	14.3	14.3	14.3	14.3	14.3	13.8	13.8
<b>Cooling Operating Range</b>	°F	64-118	64-118	64-118	64-118	64-118	64-118	64-118
	°C	17.8-47.8	17.8-47.8	17.8-47.8	17.8-47.8	17.8-47.8	17.8-47.8	17.8-47.8
<b>Outdoor Noise Level</b>	dB(A)	60	60	63	63	65	65	63
<b>Refrigerant Oil</b>	ml	740	740	740	740	1280	1280	1280
	oz	25	25	25	25	43	43	43
<b>Net Dimensions (WXHxD)</b>	mm	600×633×600	600×633×600	600×633×600	740×633×740	740×835×740	740×835×740	740×835×740
	in	23-5/8×25×23-5/8	23-5/8×25×23-5/8	23-5/8×25×23-5/8	29-1/8×25×29-1/8	29-1/8×32-7/8×29-1/8	29-1/8×32-7/8×29-1/8	29-1/8×32-7/8×29-1/8
<b>Net Weight/Gross Weight</b>	kg	54.5/57	55.5/58	63/65.5	72.5/75.5	90/95	92/97	93/98
	Lbs	120/126	122/128	137/144	160/166	198/209	203/214	205/216



Submittal Sheet for Saturn Series

Cooling Only Outdoor Unit	Heat Pump Outdoor Unit	Air Handler	Front Return Air Handler
ATSCV4C4T18	ATSCV4H4T18	ATSEM4H4T18	ATFR4H4T18
ATSCV4C4T24	ATSCV4H4T24	ATSEM4H4T24	ATFR4H4T24
ATSCV4C4T30	ATSCV4H4T30	ATSEM4H4T30	ATFR4H4T30
ATSCV4C4T36	ATSCV4H4T36	ATSEM4H4T36	ATFR4H4T36
ATSCV4C4T42	ATSCV4H4T42	ATSEM4H4T42	
ATSCV4C4T48	ATSCV4H4T48	ATSEM4H4T48	
ATSCV4C4T60	ATSCV4H4T60	ATSEM4H4T60	

Refrigerant		R410A						
Refrigerant Charge	grams	2650	2900	2900	3300	4300	4500	4600
	oz	93.50	102.30	102.30	116.40	151.70	158.70	162.30
Outer Diameter Liquid Pipe	mm	Φ9.5	Φ9.5	Φ9.5	Φ9.5	Φ9.5	Φ9.5	Φ9.5
	in	Φ3/8	Φ3/8	Φ3/8	Φ3/8	Φ3/8	Φ3/8	Φ3/8
Outer Diameter Gas Pipe	mm	Φ19.1	Φ19.1	Φ19.1	Φ19.1	Φ19.1	Φ22.2	Φ22.2
	in	Φ3/4	Φ3/4	Φ3/4	Φ3/4	Φ3/4	Φ7/8	Φ7/8



Submittal Sheet for Saturn Series

Cooling Only Outdoor Unit	Heat Pump Outdoor Unit	Air Handler	Front Return Air Handler
ATSCV4C4T18	ATSCV4H4T18	ATSEM4H4T18	ATSEFR4H4T18
ATSCV4C4T24	ATSCV4H4T24	ATSEM4H4T24	ATSEFR4H4T24
ATSCV4C4T30	ATSCV4H4T30	ATSEM4H4T30	ATSEFR4H4T30
ATSCV4C4T36	ATSCV4H4T36	ATSEM4H4T36	ATSEFR4H4T36
ATSCV4C4T42	ATSCV4H4T42	ATSEM4H4T42	
ATSCV4C4T48	ATSCV4H4T48	ATSEM4H4T48	
ATSCV4C4T60	ATSCV4H4T60	ATSEM4H4T60	

Model		ATSCV4H4T18	ATSCV4H4T24	ATSCV4H4T30	ATSCV4H4T36	ATSCV4H4T42	ATSCV4H4T48	ATSCV4H4T60
<b>Voltage, Frequency, Phase</b>		230V, 60Hz, 1P						
<b>Cooling Capacity</b>	Btu/h	17500	22000	28000	33000	40000	45000	56000
	W	5129	6448	8206	9671	11723	13188	16412
<b>Heating Capacity</b>	Btu/h	17500	22000	26000	33000	40000	44000	53000
	W	5129	6448	7620	9671	11723	12895	15533
<b>EER</b>	Btu/Wh	11.50	11.20	11.50	11.50	11.50	11.50	11.50
<b>SEER</b>	Btu/Wh	14.3	14.3	14.3	14.3	14.3	14.3	14.3
<b>HSPF</b>	Btu/Wh	7.50	7.50	7.50	7.50	7.50	7.50	7.50
<b>Cooling Operating Range</b>	°F	64-118	64-118	64-118	64-118	64-118	64-118	64-118
	°C	17.8-47.8	17.8-47.8	17.8-47.8	17.8-47.8	17.8-47.8	17.8-47.8	17.8-47.8
<b>Heating Operating Range</b>	°F	17-80	17-80	17-80	17-80	17-80	17-80	17-80
	°C	-8-26.6	-8-26.6	-8-26.6	-8-26.6	-8-26.6	-8-26.6	-8-26.6
<b>Outdoor Noise Level</b>	dB(A)	60	60	63	63	65	65	63
<b>Refrigerant Oil</b>	ml	740	740	740	740	1280	1280	1280
	oz	25	25	25	25	43.3	43.3	43.3
<b>Net Dimensions (WXHxD)</b>	mm	600×633×600	600×633×600	600×633×600	740×633×740	740×835×740	740×835×740	740×835×740
	in	23-5/8×25×23-5/8	23-5/8×25×23-5/8	23-5/8×25×23-5/8	29-1/8×25×29-1/8	29-1/8×32-7/8×29-1/8	29-1/8×32-7/8×29-1/8	29-1/8×32-7/8×29-1/8
<b>Net Weight/Gross Weight</b>	kg	57.5/60	58.5/61	66/68.5	75.5/78.5	94/99	97/102	104/109
	Lbs	127/132	129/134	146/151	166/173	207/218	214/225	229/240
<b>Refrigerant</b>		R410A						
<b>Refrigerant Charge</b>	grams	2650	2800	3000	3500	4300	4600	5600
	oz	93.50	98.80	105.80	123.50	151.70	162.30	197.50
<b>Outer Diameter Liquid Pipe</b>	mm	Φ 9.5	Φ 9.5	Φ 9.5	Φ 9.5	Φ 9.5	Φ 9.5	Φ 9.5
	in	Φ3/8	Φ3/8	Φ3/8	Φ3/8	Φ3/8	Φ3/8	Φ3/8
<b>Outer Diameter Gas Pipe</b>	mm	Φ 19.1	Φ 19.1	Φ 19.1	Φ 19.1	Φ 19.1	Φ22.2	Φ22.2
	in	Φ3/4	Φ3/4	Φ3/4	Φ3/4	Φ3/4	Φ7/8	Φ7/8



### Submittal Sheet for Saturn Series

Cooling Only Outdoor Unit	Heat Pump Outdoor Unit	Air Handler	Front Return Air Handler
ATSCV4C4T18	ATSCV4H4T18	ATSEM4H4T18	ATSEFR4H4T18
ATSCV4C4T24	ATSCV4H4T24	ATSEM4H4T24	ATSEFR4H4T24
ATSCV4C4T30	ATSCV4H4T30	ATSEM4H4T30	ATSEFR4H4T30
ATSCV4C4T36	ATSCV4H4T36	ATSEM4H4T36	ATSEFR4H4T36
ATSCV4C4T42	ATSCV4H4T42	ATSEM4H4T42	
ATSCV4C4T48	ATSCV4H4T48	ATSEM4H4T48	
ATSCV4C4T60	ATSCV4H4T60	ATSEM4H4T60	

Model	W	H	D
ATSCV4C4T18	600[23-5/8]	633[25]	600[23-5/8]
ATSCV4C4T24	600[23-5/8]	633[25]	600[23-5/8]
ATSCV4C4T30	600[23-5/8]	633[25]	600[23-5/8]
ATSCV4C4T36	740[29-1/8]	633[25]	740[29-1/8]
ATSCV4C4T42	740[29-1/8]	835[32-7/8]	740[29-1/8]
ATSCV4C4T48	740[29-1/8]	835[32-7/8]	740[29-1/8]
ATSCV4C4T60	740[29-1/8]	835[32-7/8]	740[29-1/8]
ATSCV4H4T18	740[29-1/8]	835[32-7/8]	740[29-1/8]
ATSCV4H4T24	740[29-1/8]	835[32-7/8]	740[29-1/8]
ATSCV4H4T30	740[29-1/8]	835[32-7/8]	740[29-1/8]
ATSCV4H4T36	740[29-1/8]	835[32-7/8]	740[29-1/8]
ATSCV4H4T42	740[29-1/8]	835[32-7/8]	740[29-1/8]
ATSCV4H4T48	740[29-1/8]	835[32-7/8]	740[29-1/8]
ATSCV4H4T60	740[29-1/8]	835[32-7/8]	740[29-1/8]
Units: mm [in]			

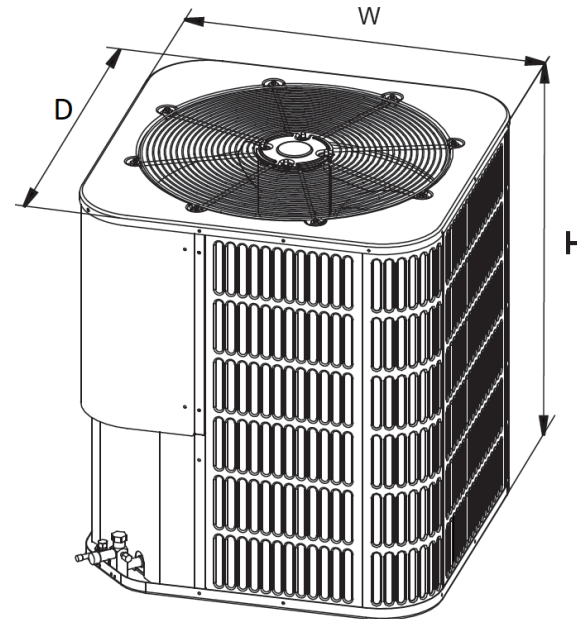



Submittal Sheet for Saturn Series

Cooling Only Outdoor Unit	Heat Pump Outdoor Unit	Air Handler	Front Return Air Handler
ATSCV4C4T18	ATSCV4H4T18	ATSEM4H4T18	ATSEFR4H4T18
ATSCV4C4T24	ATSCV4H4T24	ATSEM4H4T24	ATSEFR4H4T24
ATSCV4C4T30	ATSCV4H4T30	ATSEM4H4T30	ATSEFR4H4T30
ATSCV4C4T36	ATSCV4H4T36	ATSEM4H4T36	ATSEFR4H4T36
ATSCV4C4T42	ATSCV4H4T42	ATSEM4H4T42	
ATSCV4C4T48	ATSCV4H4T48	ATSEM4H4T48	
ATSCV4C4T60	ATSCV4H4T60	ATSEM4H4T60	

Model		ATSEM4H4T18	ATSEM4H4T24	ATSEM4H4T30	ATSEM4H4T36	ATSEM4H4T42	ATSEM4H4T48	ATSEM4H4T60
<b>Voltage, Frequency, Phase</b>		208~230V, 60Hz, 1P						
<b>Cooling Capacity</b>	Btu/h	17500	22000	28000	33000	40000	45000	55500
	W	5129	6448	8206	9671	11723	13188	16265
<b>Max. fuse/breaker (IU)</b>	A	3	3	3	6	6	6	6
<b>SEER</b>	Btu/Wh	14.30	14.30	14.30	14.30	14.30	13.80/14.30	13.80/14.30
<b>Indoor air flow</b>	m <sup>3</sup> /h	985	1359	1665	1954	2175	2684	2667
	CFM	580	800	980	1150	1280	1580	1570
<b>Net Dimensions (WXHxD)</b>	mm	500×1162×560	500×1162×560	500×1162×560	500×1162×560	500×1162×560	560×1350×623	560×1350×623
	in	19-11/16×45-3/4×22	19-11/16×45-3/4×22	19-11/16×45-3/4×22	19-11/16×45-3/4×22	19-11/16×45-3/4×22	22×53-1/8×24-17/32	22×53-1/8×24-17/32
<b>Net Weight/Gross Weight</b>	kg	57/62	60/65	59/64	59/64	61/66	78/84	78/84
	Lbs	126/137	132/143	130/141	130/141	134/146	172/185	172/185
<b>Outer Diameter Liquid Pipe</b>	mm	Φ 9.5	Φ 9.5	Φ 9.5	Φ 9.5	Φ 9.5	Φ 9.5	Φ 9.5
	in	Φ3/8	Φ3/8	Φ3/8	Φ3/8	Φ3/8	Φ3/8	Φ3/8
<b>Outer Diameter Gas Pipe</b>	mm	Φ 19.1	Φ 19.1	Φ 19.1	Φ 19.1	Φ 19.1	Φ22.2	Φ22.2
	in	Φ3/4	Φ3/4	Φ3/4	Φ3/4	Φ3/4	Φ7/8	Φ7/8



### Submittal Sheet for Saturn Series

Cooling Only Outdoor Unit	Heat Pump Outdoor Unit	Air Handler	Front Return Air Handler
ATSCV4C4T18	ATSCV4H4T18	ATSEM4H4T18	ATSEFR4H4T18
ATSCV4C4T24	ATSCV4H4T24	ATSEM4H4T24	ATSEFR4H4T24
ATSCV4C4T30	ATSCV4H4T30	ATSEM4H4T30	ATSEFR4H4T30
ATSCV4C4T36	ATSCV4H4T36	ATSEM4H4T36	ATSEFR4H4T36
ATSCV4C4T42	ATSCV4H4T42	ATSEM4H4T42	
ATSCV4C4T48	ATSCV4H4T48	ATSEM4H4T48	
ATSCV4C4T60	ATSCV4H4T60	ATSEM4H4T60	

Model	W	H	D
ATSEM4H4T18	500[19-11/16]	1162[45-3/4]	560[22]
ATSEM4H4T24	500[19-11/16]	1162[45-3/4]	560[22]
ATSEM4H4T30	500[19-11/16]	1162[45-3/4]	560[22]
ATSEM4H4T36	500[19-11/16]	1162[45-3/4]	560[22]
ATSEM4H4T42	500[19-11/16]	1162[45-3/4]	560[22]
ATSEM4H4T48	560[22]	1350[53-1/8]	623[24-17/32]
ATSEM4H4T60	560[22]	1350[53-1/8]	623[24-17/32]
Units: mm [in]			

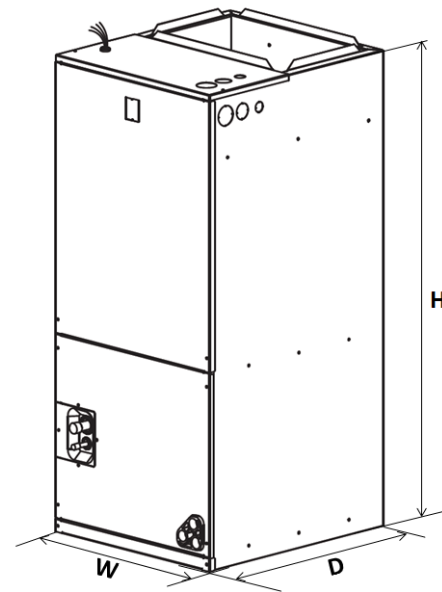



Submittal Sheet for Saturn Series

Cooling Only Outdoor Unit	Heat Pump Outdoor Unit	Air Handler	Front Return Air Handler
ATSCV4C4T18	ATSCV4H4T18	ATSEM4H4T18	ATSFR4H4T18
ATSCV4C4T24	ATSCV4H4T24	ATSEM4H4T24	ATSFR4H4T24
ATSCV4C4T30	ATSCV4H4T30	ATSEM4H4T30	ATSFR4H4T30
ATSCV4C4T36	ATSCV4H4T36	ATSEM4H4T36	ATSFR4H4T36
ATSCV4C4T42	ATSCV4H4T42	ATSEM4H4T42	
ATSCV4C4T48	ATSCV4H4T48	ATSEM4H4T48	
ATSCV4C4T60	ATSCV4H4T60	ATSEM4H4T60	

Model		ATSFR4H4T18	ATSFR4H4T24	ATSFR4H4T30	ATSFR4H4T36
<b>Voltage, Frequency, Phase</b>		208~230V, 60Hz, 1P			
<b>Cooling Capacity</b>	Btu/h	17500	22000	28000	33000
	W	5129	6448	8206	9671
<b>Max. fuse/breaker (IU)</b>	A	3	3	6	6
<b>SEER</b>	Btu/Wh	14.30	14.30	14.30	14.30
<b>Indoor air flow</b>	m <sup>3</sup> /h	1215	1368	1733	1945
	CFM	715	805	1020	1145
<b>Net Dimensions (WXHxD)</b>	mm	524×915×381	524×915×381	562×1006×485	562×1006×485
	in	20-5/8×36×15	20-5/8×36×15	22-1/8×39-39/64×19	22-1/8×39-39/64×19
<b>Net Weight/Gross Weight</b>	kg	40/44	40/44	51/56	51/56
	Lbs	88/97	88/97	112/123	112/123
<b>Outer Diameter Liquid Pipe</b>	mm	Φ 9.5	Φ 9.5	Φ 9.5	Φ 9.5
	in	Φ3/8	Φ3/8	Φ3/8	Φ3/8
<b>Outer Diameter Gas Pipe</b>	mm	Φ 19.1	Φ 19.1	Φ 19.1	Φ 19.1
	in	Φ3/4	Φ3/4	Φ3/4	Φ3/4



### Submittal Sheet for Saturn Series

Cooling Only Outdoor Unit	Heat Pump Outdoor Unit	Air Handler	Front Return Air Handler
ATSCV4C4T18	ATSCV4H4T18	ATSEM4H4T18	ATSFR4H4T18
ATSCV4C4T24	ATSCV4H4T24	ATSEM4H4T24	ATSFR4H4T24
ATSCV4C4T30	ATSCV4H4T30	ATSEM4H4T30	ATSFR4H4T30
ATSCV4C4T36	ATSCV4H4T36	ATSEM4H4T36	ATSFR4H4T36
ATSCV4C4T42	ATSCV4H4T42	ATSEM4H4T42	
ATSCV4C4T48	ATSCV4H4T48	ATSEM4H4T48	
ATSCV4C4T60	ATSCV4H4T60	ATSEM4H4T60	

Model	W	H	D
ATSFR4H4T18	524[20-5/8]	915[36]	381[15]
ATSFR4H4T24	524[20-5/8]	915[36]	381[15]
ATSFR4H4T30	562[22-1/8]	1006[39-39/64]	485[19]
ATSFR4H4T36	562[22-1/8]	1006[39-39/64]	485[19]
Units: mm [in]			

